



MACHINERY DIVISION

6465 18 MILE ROAD
STERLING HEIGHTS, MI 48314

PHONE:
(586) 731-3600 • 1-800-860-1740

FAX:
(586) 731-7464 • 1-800-862-1740

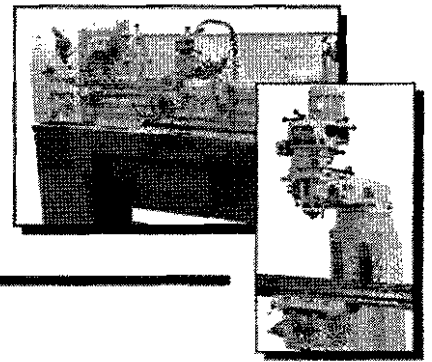

MODEL BAH-5 BANDSAW

THANK YOU FOR PURCHASING WITH KBC MACHINERY. ALL KBC MACHINES ARE BACKED BY OUR 1 YEAR PARTS REPLACEMENT WARRANTY. WHEN USED AS INTENDED, AND WITH PROPER MAINTENANCE THIS MACHINE WILL PROVIDE YOU WITH YEARS OF TROUBLE-FREE SERVICE. IF YOU NEED PARTS SIMPLY FILL OUT THE PARTS REQUEST FORM, AND FAX OR E-MAIL YOUR REQUEST. ALL OTHER QUESTIONS PLEASE CONTACT US @ :

**KBC MACHINERY
6465 18 MILE ROAD
STERLING HEIGHTS, MI 48314
PH (800) 860-1740
FAX (800) 862-1740
MACHINERY@KBCTOOLS.COM
WWW.KBCTOOLSANDMACHINERY.COM**



PARTS REQUEST FORM

YOUR COMPANY NAME:

STATE/PROVINCE

YOUR NAME

PHONE # + EXT

FAX #

MACHINE INFO:

MAKE/MANUFACTURER

MODEL NUMBER

YEAR MADE

SERIAL#

PARTS REQUESTED:

PART#

DESCRIPTION

PLEASE INCLUDE COPY(S) OF THE PARTS DRAWING FROM THE
MANUAL AND CIRCLE THE PARTS NEEDED

FAX PARTS REQUEST TO (800) 862-1740

E-MAIL PARTS REQUEST TO: machinery@kbctools.com

THANKS; KBC MACHINERY - MICHIGAN

4 $\frac{1}{2}$ " METAL CUTTING BANDSAW INSTRUCTION MANUAL BAH-5

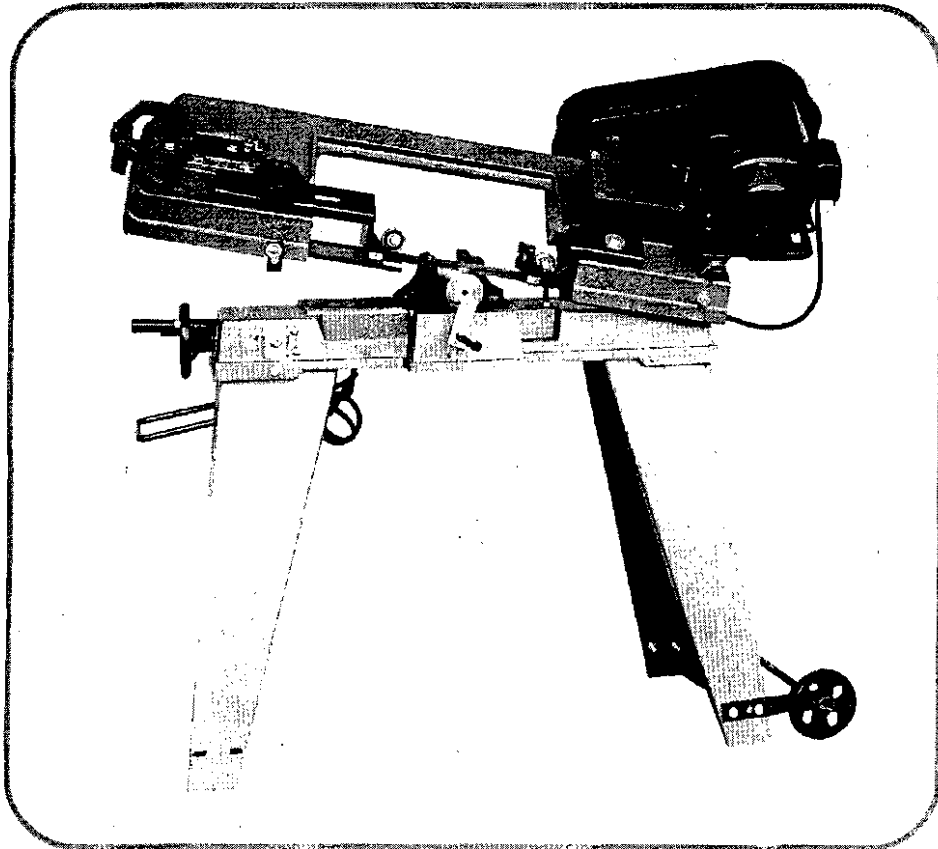

Combination

Horizontal and

Vertical Position



Warning: Some dust created by power sanding, sawing, grinding, drilling and other construction activities contain chemicals known to the State of California to cause cancer, birth defects or other reproductive harm. Some examples of these chemicals are lead (from lead based paint), crystalline silica (from bricks, cement and other masonry products), and arsenic and chromium (from chemically treated lumber). Your risk from these exposures varies, depending on how often you do this type of work. To reduce you exposure to these chemicals, work in a well-ventilated area and work with approved safety equipment such as those dust masks that specially designed to filter our microscopis particles.

TABLE OF CONTENTS

General Safety Rules.....	1-2
Additional Safety Rules.....	3
Motor Specifications and Electrical Requirement.....	4-5
Getting to know your Bandsaw.....	6
Unpacking and Checking contents.....	7
Tools Needed to Assemble.....	7
Adjusting Blade Guide Bearing.....	8
Adjusting Blade Support Bearing.....	8
Adjusting Blade Tension.....	9
Adjusting Blade Tracking.....	9
Changing Specds and Adjusting Belt Tension.....	10
Speed and Material CHART.....	10
Adjusting Blade 90 Degree to the Table Surface.....	11
Adjusting Blade Guide Brackets.....	11
Operating and Adjusting the Vise.....	12
Adjusting Stock Stop.....	12
Changing Saw from Horizontal to Vertical Position.....	13
Changing Blade.....	14
Blade Selection.....	14
Maintenance.....	15
Repair Parts List and Schematic.....	16-18

GENERAL SAFETY RULES

WARNING

"Read all instructions" Failure to follow the safety rules listed below and other basic safety precautions may result in serious personal injury.

WORK AREA

Keep children away. All visitors should be kept safe distance from work area.

1. **KEEP WORK AREA CLEAN.** Cluttered areas and benches invite accidents.
2. **MAKE WORKSHOP CHILD PROOF** with padlocks, master switches, or by removing starter keys.
3. **AVOID DANGEROUS ENVIRONMENT.** Don't use power tools in damp or wet location, or expose them to rain. Keep work area well lit.

PERSONAL SAFETY

1. **WEAR PROPER APPAREL.** No loose clothing, gloves, neckties, rings bracelets, or other jewelry to get caught in moving parts. Nonslip footwear is recommended. Wear protective hair covering to contain long hair.
2. **ALWAYS USE SAFETY GOGGLES.** Common eyeglasses only have impact resistant lenses, they are NOT safety glasses.
3. **DISCONNECT TOOLS** before servicing; when changing accessories such as blade.
4. **KEEP GUARDS IN PLACE** and in working order.
5. **REMOVE ADJUSTING KEYS AND WRENCHES.** From habit of checking to see that keys and adjusting wrenches are removed from tool before turning it on.
6. **DON'T OVERREACII.** Keep proper footing and balance at all times.
7. **REDUCE THE RISK OF UNINTENTIONAL STARTING.** Make sure switch is in off position before plugging in.
8. **USE RECOMMENDED ACCESSORIES.** Consult the owner's manual for recommended accessories. The use of improper accessories may cause risk of injury to persons.
9. **NEVER STAND ON TOOL.** Serious injury could occur if the tool is tipped or if the cutting tool is unintentionally contacted.
10. **CHECK DAMAGE PARTS.** Before further use of the tool. A guard or other part that is damaged should be carefully checked to determine that it will operate properly and perform its intended function, check for alignment of moving parts, binding of moving parts, breakage of parts, mounting. And any other conditions that may affect its operation. A guard or other part that is

GENERAL SAFETY RULES

TOOL USE

1. **DON'T FORCE TOOL.** Don't force tool or attachment to do a job for which it was not designed.
2. **USE RIGHT TOOL.** It will do the job better and safer at the rate for which it was designed.
3. **SECURE WORK.** Use clamps or vise to hold work when practical, It's safer than using your hand and it frees both hands to operate tool.
4. **NEVER LEAVE TOOL RUNNING UNATTENDED TURN POWER OFF.** Don't leave tool until it comes to a complete stop.
5. Do not remove jammed cutoff pieces until blade has stopped.
6. Maintain proper adjustment of blade tension, blade guides, and thrust bearings.
7. Adjust upper guide to just clear workpiece.
8. Hold workpiece firmly against table.

TOOL CARE

1. **MAINTAIN TOOLS WITH CARE.** Keep tools sharp and clean for better and safer performance. Follow instructions for lubricating and changing accessories.
2. **DO NOT ALTER OR MISUSE TOOL.** These tools are precision built. Any alteration or modification not specified is misuse and may result in dangerous condition.
3. **AVOID GASEOUS AREAS.** Do not operate electric tools in a gaseous or explosive atmosphere. Motors in these tools normally spark and may result in a dangerous condition.

WARNING

Before connecting the tool to a power source (receptacle, outlet, ETC) be sure the voltage supplied is the same as that specified on the nameplate of the tools. A power source with a voltage greater than that specified for the tool can result in serious injury to the user as well as damage to the tool. If in doubt. **DO NOT PLUG IN THE TOOL.** Using a power source with a voltage less than the nameplate rating is harmful to the motor.

ADDITIONAL SAFETY RULES

THINK SAFETY

SAFETY IS A COMBINATION OF OPERATOR COMMON SENSE AND ALERTNESS AT ALL TIMES WHEN THE BANDSAW BEING USED.

WARNING Do not allow familiarity (gained from frequent use of your bandsaw) to become commonplace. Always remember that a careless fraction of a second is sufficient to inflict severe injury.

WARNING The operation of any power tool can result in foreign objects being thrown into the eyes which can result in severe eye damage. Always wear safety goggles before commencing power tool operation.



LOCATION

Use the bandsaw in a well lit area and on a level surface, clean and smooth enough to reduce the risk of tripps and falls. Use it where neither the operator nor the casual observer is forced to stand in line with a potential kickback.

POTECTION: EYES, HANDS, FACE, EARS AND BODY.

WARNING TO AVOID BEING PULLED INTO THE BITS.

DO NOT WEAR: LOOSE FITTING GLOVES
NECKTIE
LOOSE CLOTHING
JEWELRY

DO TIE BACK LONG HAIR
ROLL LONG SLEEVES ABOVE ELBOWS

WARNING Never place your fingers in a position where they could contact the bits. If the workpiece should unexpectedly shift or your hand should slip.

WARNING If any part of your bandsaw is missing, malfunctioning, has been damaged or broken... such as the motor switch or other operating control, a safety device or the power cord... cease operating immediately until the particular part is property repaired or replace.

MOTOR SPECIFICATIONS AND ELECTRICAL REQUIREMENTS

MOTOR SPECIFICATIONS

This bandsaw is designed to use a 1720 RPM motor only. Do not use any motor that runs faster than 1720 RPM. It is wired for operating on 110-120volts, 60. Hz alternating current.



To avoid injury from unexpected start-up, do not use blower or washing machine motors or any motor with an automatic reset overload protector.

MOTOR SPECIFICATIONS

This machine must be grounded while in use to protect the operator from electric shock.

Plug power cord into a 110-120V properly grounded type outlet protected by a 15-amp dual element time delay fuse or circuit breaker.

Not all outlets are properly grounded. If you are not sure that your outlet, as picture below, is properly grounded, have it checked by a qualified electrician.



To avoid electric shock, do not touch the metal prongs on the plug when installing or removing the plug to or from the outlet.

Failure to properly ground this power tool can cause electrocution or serious shock, particularly when used near metal plumbing or other metal objects. If shocked, your reaction could cause your hands to hit the cutting tool.



If power cord is worn or cut, or damaged in any way, have it replaced immediately to avoid shock or fire hazard.

Your unit is for use on 120 volts; it has a plug that looks like the one below.

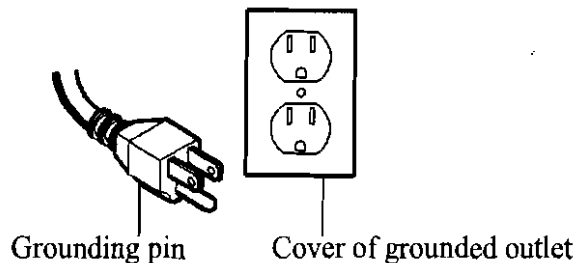

MOTOR SPECIFICATIONS AND ELECTRICAL REQUIREMENTS

This power tool is equipped with a 3-conductor cord and grounding type plug . The ground conductor has a green jacket and attached to the tool housing at one end and to the ground prong in the attachment plug at the other end.

This plug requires a mating 3-conductor grounded type outlet as pictured.

If the outlet you are planning to use for this power tool is of the two-prong type. **DO NOT REMOVE OR ALTER THE GROUNDING PRONG IN ANY MANNER.** Use an adapter as shown and always connect the grounding lug to known ground.

It is recommended that you have a qualified electrician replace the TWO-prong outlet with a properly grounded THREE-prong outlet.

An adapter as shown below is available for connecting plugs to 2-prong recap-tacles.

WARNING

The green grounding lug extending from the adapter must be connected to a permanent ground such as a properly grounded outlet box.

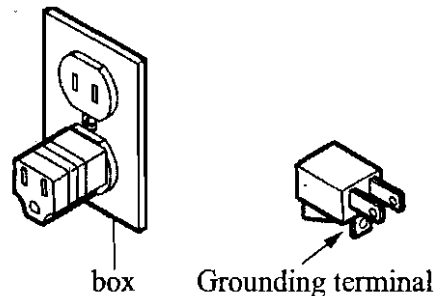

NOTE: The adapter illustrated is for use only if you already have a properly grounded 2-prong receptacles. Adapter is not allowed in Canada by Canadian Electrical Code.

The use of any extension cord will cause some loss of power, To keep this to a minimum and to prevent overheating and motor burn-our, use the table below to determine the minimum wire size (A.W.G.) for an extension cord. Use only 3-wire extension cords which have 3-prong grounding type plugs and 3-pole receptacles which accept the tool's plug.

Extension Cord Length	Wire Size A.W.G.
0-25 Feet	16
26-50 Feet	14
51-100 Feet	12

GETTING TO KNOW YOUR BANDSAW

1. STAND

Supports bandsaw, for additional stability, holes are provided in stand. (when wheel assembly is removed) to bolt bandsaw to a supporting surface.

2. HANDLE TO ASSIST MOVING THE BANDSAW TO A NEW LOCATION

To move bandsaw by lifting stand handle.

3. PULLEY COVER

Covers pulleys and belt during operation of bandsaw.

4. METAL STOP

Stop come down to hit switch that will shut off machine automatically right After cutting is finished when machine is in the horizontal position.

5. VERTICAL TABLE

Provides working surface to support work when use in the vertical position.

6. VISE PLATE

Provides means to tighten and hold work securely from 0 to 45 degree.

7. WHEELS

Allows you to easily move machine and support bandsaw when it is lin the Vertical position.

8. STOP BOLT N LOCK NUT

Controls lowest cutting position.

9. BLADE SUPPORT BEARING/GUIDE BEARING

Keeps blade on proper tracking.

10. BLADE TENSION ADJUSTMENT KNOB

Controls blade tension.

11. BLADE GUIDE ADJUSTMENT KNOB

Adjusts blade guide brackets to accommodate the width of the workpiece.

12. BLADE ADJUSTMENT SCREW

Adjusts blade to proper position.

13. STOCK STOP

Used when more than one piece is to be cut at the same length.

14. PRESSURE ADJUSTMENT HANDLE

Increases or decreases feed pressure.

15. SWITCH SAFETY BRACKET

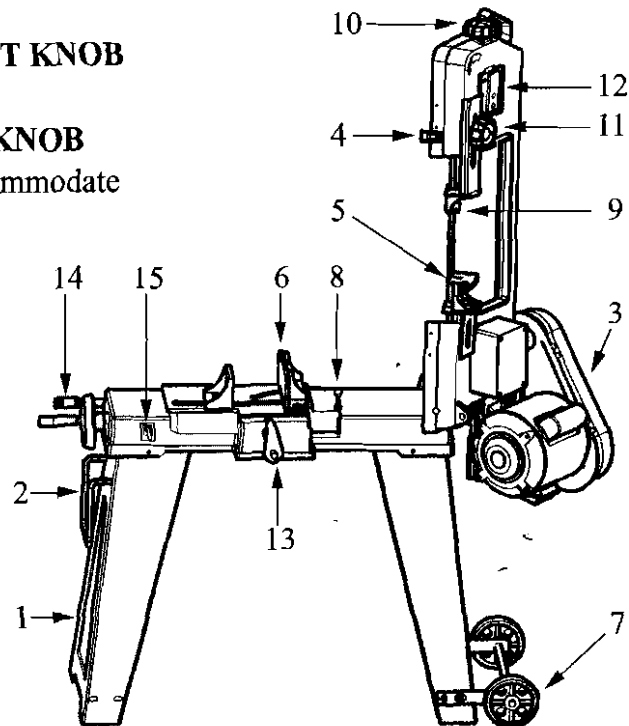

UNPACKING AND CHECKING CONTENTS

WARNING

- (1) To avoid injury from unexpected starting or electrical shock. Do not plug the power cord into a source of power. This cord must remain unplugged whenever you are work-ing on the bandsaw.
- (2) Unpacking and checking contents. Separate all "loose parts" from pack-aging materials and check each item with "Table of loose parts" to make sure all items are accounted for before discarding any packing material. If any parts are missing, do not attempt to assemble band-saw, plug in the power cord, or turn the switch on, until missing parts are obtained and are installed correctly.
- (3) To avoid fire or toxic reaction, never use gasoline, naphtha or simi-lar highly votatile solvents.
- (4) Apply a coat of paste wax to the table and base, to prevent rust. Wipe all parts thoroughly with a clean dry cloth.

ON-OFF SWITCH PADLOCK

To safeguard the band saw from unauthorized operation and to avoid accidental starting by children, the use of padlock is requested. To lock out the on-off switch, open the padlock, insert through the holes in the switch guards, and close the padlock. Place the key in a location that is inaccessible to children and others not qualified to use the tool.

TOOLS NEEDED TO ASSEMBLE

6" Adjustable Wrench, #2 Phillips Screw Driver, 1/4" flat Screw Driver and Allen Wrence (4 MM) and Lock.

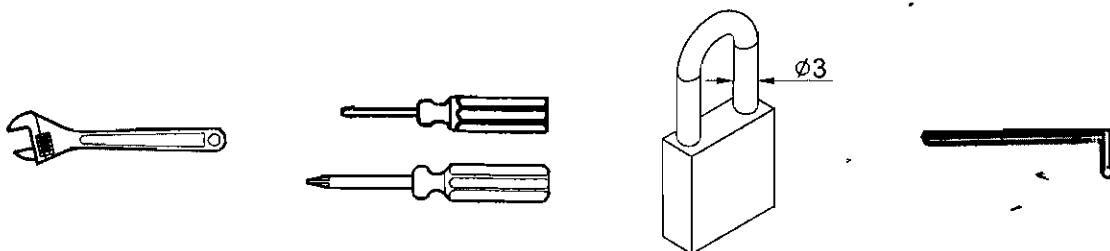

OPERATING CONTROLS AND ADJUSTMENTS

The downward travel of the saw should be adjusted to just trip the toggle switch at its lowest position. To adjust the downward travel of the saw arm, loosen lock nut (C)(see figure), and turn the stop screw (D) in or out until the correct adjustment is made; then tighten lock nut (C).

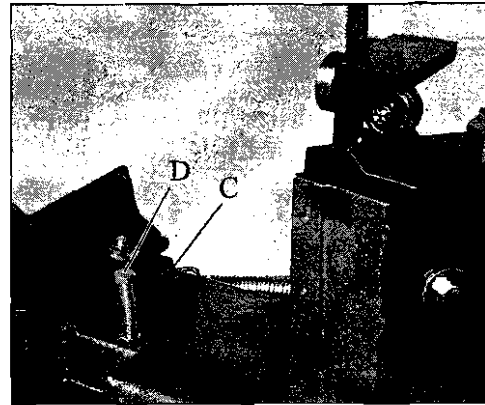

ADJUSTING BLADE GUIDE BEARINGS

1. Disconnect the machine from the power source.
2. The blade guide bearings (A) and (B) (see figure), should be adjusted so they just touch the sides of the blade (C) after the blade is tracking properly and the blade support bearing has been adjusted. To adjust, proceed as follows;
3. Remove the cover plate that is attached to the face of the right guide bracket (D) (see figure).
4. The inside guide bearing (A) (see figure) is mounted to a fixed shaft and cannot be adjusted. The outside guide bearing (B) is mounted on an eccentric shaft and should be adjusted so that the sides of the blade (C) just contact the guide bearings (A) and (B) to adjust, loosen screw (E) until proper adjustment is made. Then tighten screw (E).
5. Adjust the other blade guide bearings in the same manner.

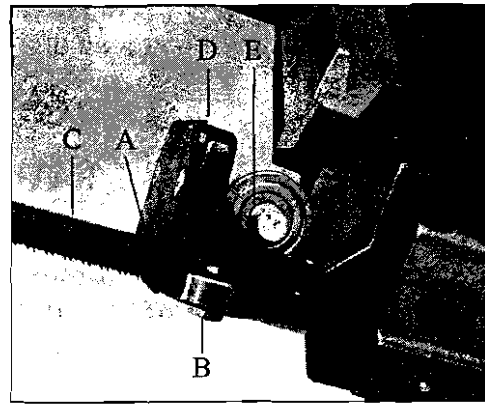

ADJUSTING BLADE SUPPORT BEARING

1. Disconnect the machine from the power source.
2. The blade support bearing (A) (see figure) should be adjusted so it just touches the back of the saw blade after the blade is tracking properly.
3. Adjust the other blade support bearing in the same manner.

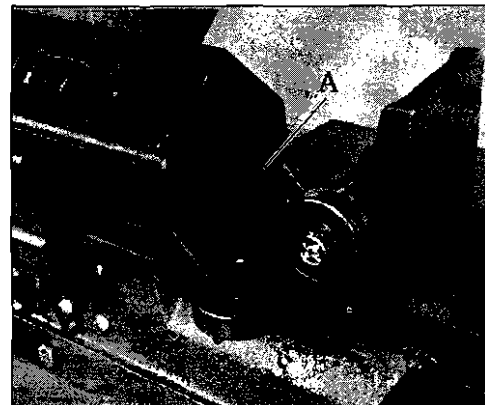

OPERATING CONTROLS AND ADJUSTMENTS

ADJUSTING BLADE TENSION

- Turn blade tension handwheel (A) (see figure), clockwise to increase or counterclockwise to decrease blade tension. Correct tension is obtained when the blade is just tight enough so that no slippage occurs between the blade and the wheels.
- When the machine is not in use, release the blade tension.

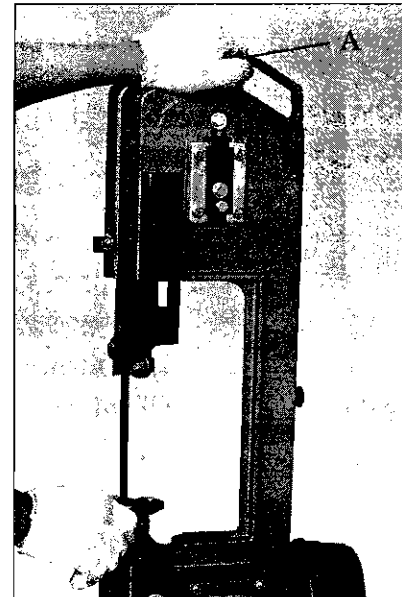

ADJUSTING BLADE TRACKING

1. Place the saw arm in the vertical position and open the wheel cover (A) (see figure-1).
2. Turn on the band saw. The blade is tracking properly when the back of the blade (B) (see figure-1), is just touching the edge of the wheel flange (C). The back of the blade should not be rubbing against the flange.
3. If an adjustment is necessary, the blade guide bearings and blade support bearings should be clear of the blade.
4. Loosen screw (D) (see figure-2) to a point where it is loose but snug.
5. With the band saw running, turn adjusting screw (E) until the blade is tracking properly making certain blade tension is maintained by turning blade tension knob (F). The blade is tracking properly when the back side of the saw blade just touches the flange on the wheel.
6. Tighten screw (D) (see figure-2) when adjustment is complete.
7. IMPORTANT: IT IS POSSIBLE WHEN MAKING THIS

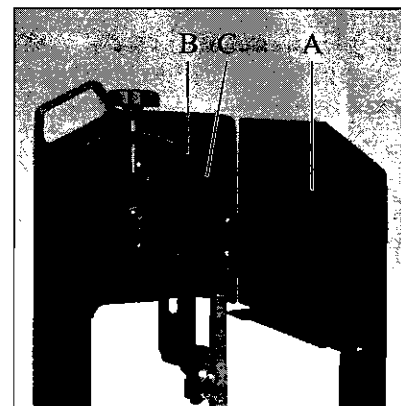

ADJUSTMENT TO OVER TIGHTEN THE
ADJUSTING

SCREW (E) (SEE FIGURE-2) AND CAUSE THE
BASIC

SETTING TO BE MIS-ALIGNED.

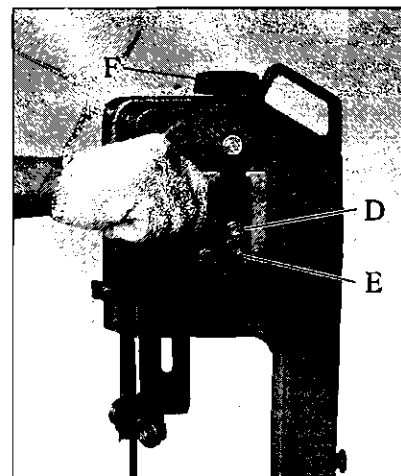

OPERATING CONTROLS AND ADJUSTMENTS

CHANGING SPEEDS AND ADJUSTING BELT TENSION

Disconnect machine from the power source before changing speeds and adjusting belt tension.

Proper belt tension is obtained when there is approximately 1/4" deflection of the belt using light finger pressure at the center span of the pulleys. To adjust belt tension, loosen lock nut (A) (see figure 1) and turn adjusting screw (B) clockwise to increase tension and counter-clockwise to decrease tension. Tighten locknut (A) (see figure-1) after belt tension is obtained.

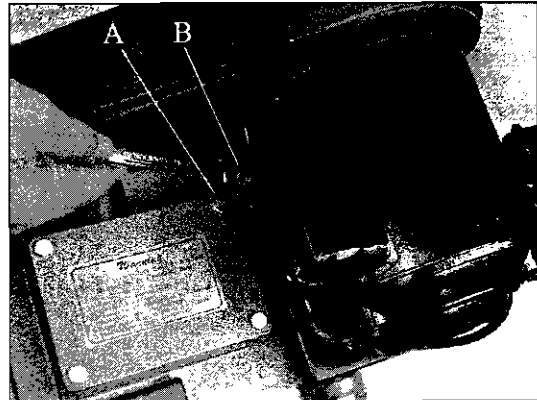

When changing speeds, release belt tension and open belt and pulley guard cover (D) (see figure-2). Speed rates of 80, 120, and 200 feet per minute are available with your band saw. When the belt is on the largest step of the motor pulley (A) (see figure-2), and the smallest step of the gear box pulley (B) the blade speed will be 200 feet per minute. When the belt is on the smallest step of the motor pulley (A) and the largest step of the gear box pulley (B) the blade speed will be 80 feet per minute. When changing speeds, first release belt tension. After the desired speed is obtained, adjust belt tension and close belt and pulley guard cover (D).

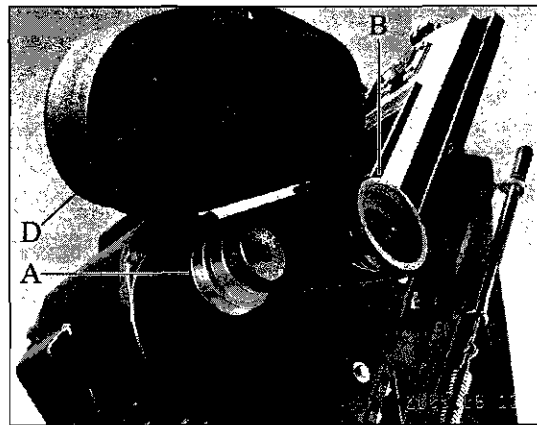

SPEED AND MATERIAL CHART

Chart illustrates the correct speeds and the position of the belt on the motor and gear box pulleys for most common materials cut on the bandsaw.

MATERIAL TO BE CUT	SPEED	BELT POSITION	
		MOTOR PULLEY	GEAR BOX PULLEY
Tool Steel Stainless Steel Alloy Steel Hard Bronze	80FPM	Small	Large
Mild Steel Medium Hard Brass Medium Hard Bronze	120FPM	Middle	Middle
Soft Brass Aluminum Plastic Other Light Materials	200FPM	Large	Small

OPERATING CONTROLS AND ADJUSTMENTS

ADJUSTING BLADE GUIDE BRACKETS

The left and right blade guide brackets (A) and (B), are adjustable by lock knobs (C) and sliding the brackets to accommodate the width of the workpiece. The guide brackets should be set as close as possible to the workpiece, as shown in (see figure), without interfering with the workpiece or contacting the table. Once the adjustment is made, tighten the lock knobs (C).

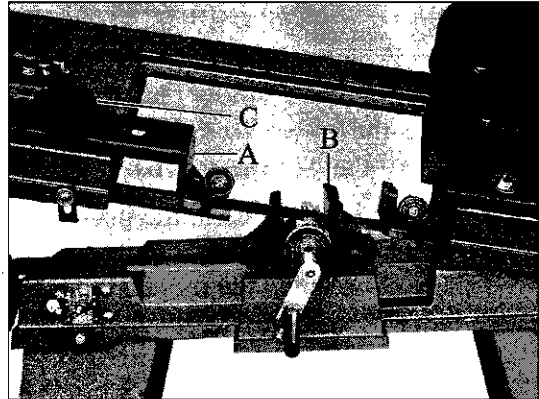

ADJUSTING FEED RATE

The feed rate of the saw arm can be adjusted by turning the control arm (see figure) counter-clockwise to increase or clockwise to decrease the feed rate. Do not turn the control arm more than one turn at a time. Excessive feed pressure can break the blade. Insufficient feed pressure dulls the blade rapidly.

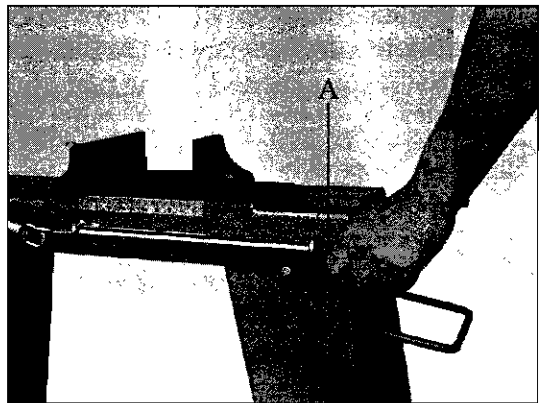

ASSEMBLE THE BLADE SAFE PLATE

1. Assemble the blade safe plate (A) to the blade guard (B) using the screws (see figure)
2. Assemble the blade safe plate (C) to the blade guard (D) using the screws (see figure)

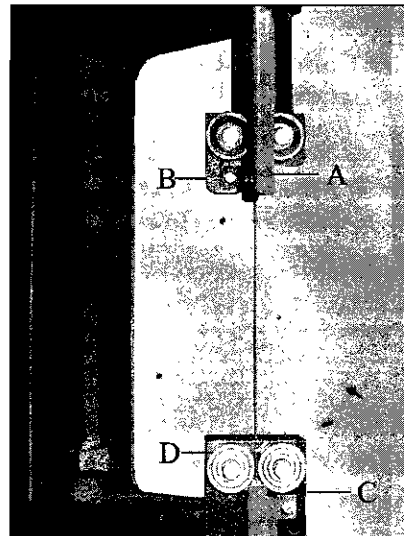

OPERATING CONTROLS AND ADJUSTMENTS

OPERATING AND ADJUSTING THE VISE

See Figure 1.

1. The workpiece (A) is placed between the vise jaws with the required amount to be cut off extending out past the blade. To tighten the workpiece in the vise, turn the handwheel (B).
2. This machine, if used in the horizontal position, will shut off automatically after cutting is finished. This is done when the metal stop (C) hits the switch (D), causing the machine to shut off.

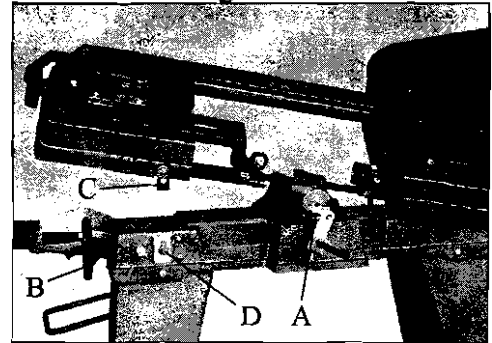
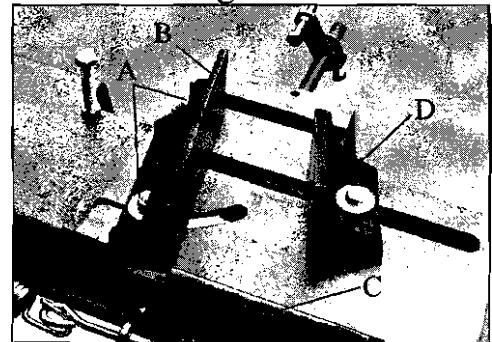

Figure 2.

See Figure 2.

3. The vise can be adjusted to cut any angle from 00-450 by loosening the two screws (A) and positioning the vise jaw (B) to the desired angle. A scale (C) is positioned on the rear of the table to give the proper cutting angle.

Note: When cutting at an angle, it may also be necessary to move the left vise jaw (D) to clear the blade guide bracket.



ADJUSTING STOCK STOP

The stock stop is used when more than one piece is to be cut to the same length.

See Figure 3.

1. Position the stop block (A) the desired distance away from the blade. It is good practice to have the work contact the stop near the bottom of the work, as shown.
2. The stop can slide in or out by loosening the set screw (B) and moving the stop.
3. When not using the stock stop simply swing the stop out of the way below the table surface.

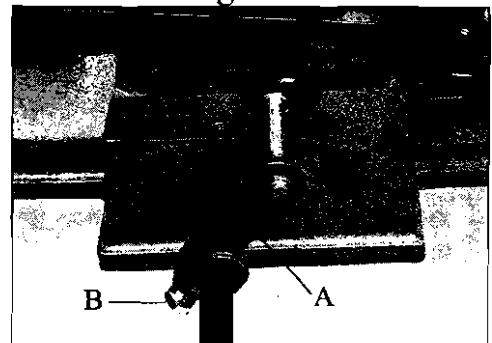
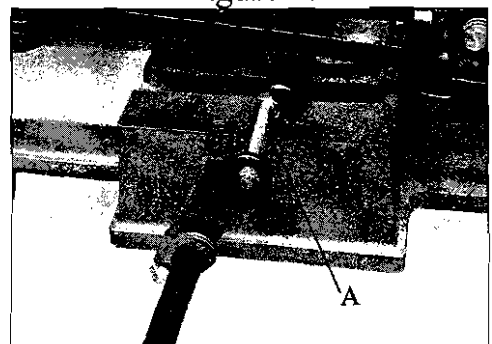

Figure 4.

See Figure 4.

4. For cuts where the work will not extend beyond the table, the Bolt (A) on the stop can be adjusted to contact the workpiece.



BASIC OPERATION

CHANGING SAW FROM HORIZONTAL TO VERTICAL POSITION

Your saw can be changed to the vertical position notching, slitting or contour work as follows;

1. Disconnect the machine from the power source.
2. Move the cutting arm to the vertical position (loosen the tension on the coil spring by turning the handle, and the cutting arm will stay up)
3. Remove two screws (A) and bearing cover plate (B).(see figure-1)
4. Assemble the vertical table (C) to the guide bracket using the two screws (D), as shown in (see figure-2).

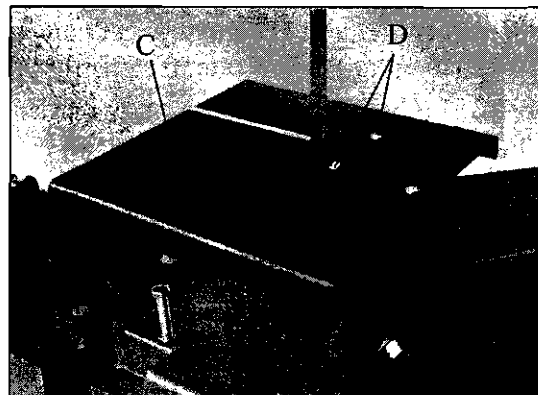
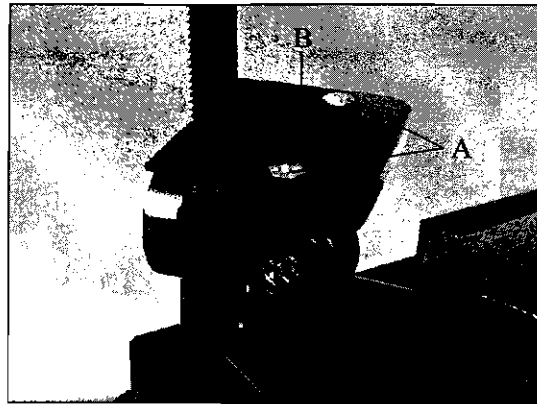

BASIC OPERATION

CHANGING BLADES

1. Disconnect the machine from the power source.
2. Raise the saw arm to the vertical position and open the blade wheel cover (A) (see figure).
3. Release blade tension by turning blade tension hand knob (B).
4. Remove the two finger guards (C).
5. Slip blade (D) off both wheels (E) and guide assemblies (F).
6. Place the blade between each of the blade guide bearings (F) and around both wheels (E). NOTE: The teeth must be pointing down on the right hand side as shown by the directional arrow in.
7. Replace finger guard (C) and adjust blade tension by turning hand knob (B).
8. Close the blade wheel cover (A).

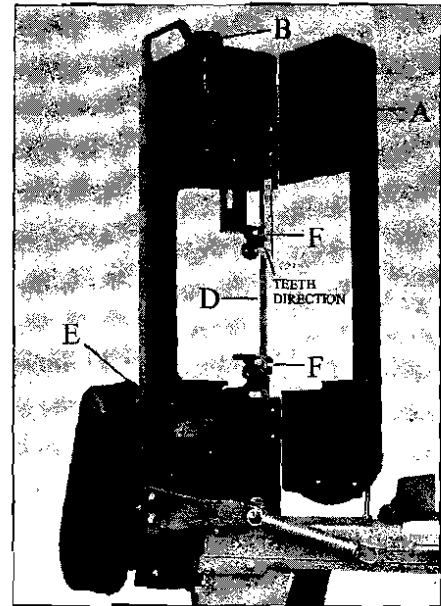

BLADE SELECTION

1. Your band saw uses 1/2" wide, 64-1/2" wide, 64-1/2" long and .020-.025 thick. 14 teeth per inch and 24 teeth per inch blades.
2. Never use a blade so coarse that less than three consecutive teeth are engaged in the workpiece at one time. (Too few teeth will cause the teeth to strip out.)
3. Never use a blade finer than required to obtain a satisfactory surface finish or satisfactory flatness (Too many teeth engaged in the workpiece will prevent attainment of a satisfactory sawing rate, frequently produce "dished" cuts or cuts which are neither square or parallel).
4. When thin rectangular solid bar is to be sawed, the work should, whenever possible, be loaded with the thinnest cross section exposed to the blade teeth. The pitch (number of teeth per inch of blade) selected must provide engagement of at least three consecutive teeth in the workpiece should application of this rule not be possible because the thinnest cross section is too thin, the piece must be loaded with the wider dimension exposed to the saw teeth and a coarse blade selected.
5. When thin wall pipe or channel iron are cut a 14 pitch (number of teeth per inch of blade) is used. Fewer than 14 teeth per inch will almost never be satisfactory.

MAINTENANCE

LUBRICATION

The vise lead screw should be lubricated using light machine oil as needed.

The drive gears run in an oil bath gear box and it should not be necessary to change this oil more than once a year unless the oil becomes contaminated or a leak occurs due to improper replacement of the gear box cover. To change oil in the gear box, proceed as follows:

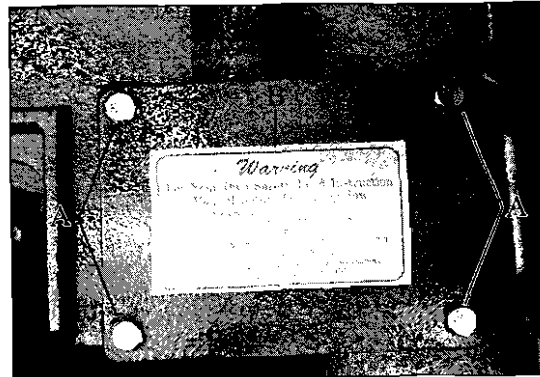

1. Disconnect the machine from the power source.
2. Position cutting arm in the horizontal position.
3. Remove the four screws (A) (see figure-1), and the gear box cover (B) and gasket.
4. Remove the old oil from inside the gear box and replace the oil using 140 weight gear oil. The new oil should just come to the edge (C) (see figure-2) of the gear box. Do not overflow. Replace the cover, gasket and four screws that were removed in step 3.

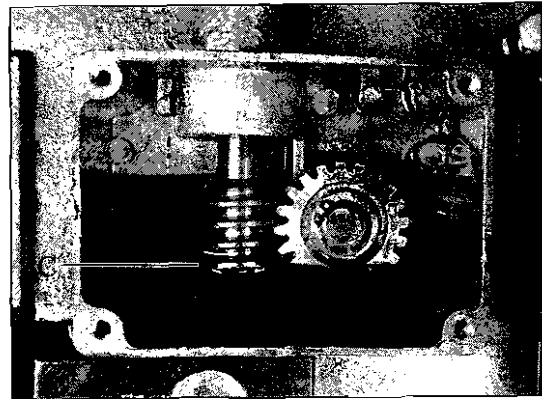

REPAIR PARTS LIST AND SCHEMATIC

PART NO.	DESCRIPTION	Q'TY
1	BASE	1
2	SUPPORTING PLATE COVER SEAT	1
3	HEX SCREW (5/16"X3/4")	9
4	WASHER	17
5	PIVOTING ROD	1
6	PLASTIC SLEEVE	1
7	STOCK STOP ROD	1
8	STOCK STOP	1
9	CORD CLAMP PLATE	2
10	PAN SCREW (3/16"X3/8")	3
11	SET SCREW (5/16"X1/4")	5
12	SWITCH ASS'Y	1
13	WISE NUT	1
14	LEAD SCREW	1
15	HANDLE WHEEL	1
16	HANDLE	1
17	SCALE	1
18	HEX NUT (3/8")	2
19	HEX SCREW (3/8"X2-1/2")	1
20	HEX SCREW (5/16"X1")	5
21	HEX NUT (5/16")	12
22	SPRING	1
23	SPRING ADJUSTING SCREW (1/4")	1
24	EYE BOLT (SMALL 5/16")	1
25	EYE BOLT (LARGE 5/16")	1
26	ADJUSTING ROD	1
27	MITERING VISE PLATE	1
28	WASHER (5/16")	5
29	HEX SCREW (3/8"X1-1/4")	1
30	HEX SCREW (3/8"X3/4")	1
31	MOVABLE VISE PLATE	1
32	PAN SCREW (3/16"X3/4")	2
33	BODY FRAME	1
34	PAN SCREW (3/16"X1/4")	6
35	BLADE BACK SAFETY COVER	1
36	BLADE TENSION ADJUSTABLE KNOB	1
37	BLADE TENSION SLIDING GUIDES	2
38	HEX SCREW (5/16"X1/2")	7
39	BLADE TENSION SLIDING PLATE	1
40	HEX SCREW (5/16"X1-1/4")	1
41	BLADE WHEEL (SHAFT)	1
42	BEARING # 6202ZZ	4
43	BLADE WHEEL (REAR)	1
44	BLADE 14T	1
45	BLADE WHEEL (FRONT)	1
46	METAL STOP	2
47	WASHER	13
48	BLADE GUARD (LEFT)	1

REPAIR PARTS LIST AND SCHEMATIC

PART NO.	DESCRIPTION	Q'TY
49	ADJUSTING KNOB	1
50	HEX SCREW (1/4"X1/2")	4
51	GUIDE PIVOT	6
52	BEARING #6200ZZ	6
53	HEX SCREW (1/4"X3/4")	20
54	SCREW (1/4"X3/8")	3
55	GUIDE PLATE	1
56	BLADE GUARD (RIGHT)	1
57	VERTICAL CUTTING PLATE	1
58	HEX SCREW (1/2"X1")	2
59	MOTOR	1
60	MOTOR PULLEY	1
61	BELT (A-23)	1
62	GEAR BOX COVER	1
63	COVER GASKET	1
64	TRANSMISSION WHEEL SEAT	1
65	GEAR BOX	1
66	OIL SEAL	2
67	PLASTIC BEARING SLEEVE	2
68	WORM GEAR	1
69	BEARING #6202ZZ	1
70	C-RING	1
71	WORM GEAR PULLEY	1
72	PULLEY COVER	1
73	PLUM SCREW	2
74	FLOOR STAND	2
75	ELECTRIC CORD	1
76	WHEEL SHAFT	1
77	WHEEL BRACKET	2
78	WHEEL	2
79	SPLIT COTTER PIN	4
80	FLOOR STAND HANDLE	1
81	HEX NUT (1/4")	10
82	SWITCH SAFETY BRACKET	1
83	SWITCH BOX	1
84	SWITCH BOX SCREW	2
85	HEX NUT (3/16")	1
86	WASHER	1
87	CORD STRAIN RELIEF	1
88	WASHER	1
89	HEX SCREW (3/8"X1-1/2")	1
90	MOTOR MOUNT PLATE	1
91	BLADE SAFETY PLATE (RIGHT)	1
92	BLADE SAFETY PLATE (LEFT)	1
93	HEX SCREW (5/16"X2")	1
95	BLADE WHEEL SAFETY COVER	1
96	HEX SCREW (1/4"X3/8")	2

REPAIR PARTS LIST AND SCHEMATIC

