

MACHINERY DIVISION

6465 18 MILE ROAD
STERLING HEIGHTS, MI 48314

PHONE:
(586) 731-3600 • 1-800-860-1740

FAX:
(586) 731-7464 • 1-800-862-1740

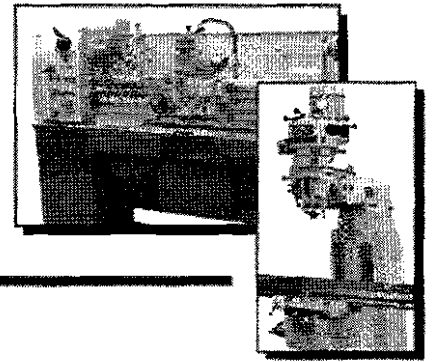

MODEL SG-612 SURFACE GRINDER

THANK YOU FOR PURCHASING WITH KBC MACHINERY. ALL KBC MACHINES ARE BACKED BY OUR 1 YEAR PARTS REPLACEMENT WARRANTY. WHEN USED AS INTENDED, AND WITH PROPER MAINTENANCE THIS MACHINE WILL PROVIDE YOU WITH YEARS OF TROUBLE-FREE SERVICE. IF YOU NEED PARTS SIMPLY FILL OUT THE PARTS REQUEST FORM, AND FAX OR E-MAIL YOUR REQUEST. ALL OTHER QUESTIONS PLEASE CONTACT US @ :

**KBC MACHINERY
6465 18 MILE ROAD
STERLING HEIGHTS, MI 48314
PH (800) 860-1740
FAX (800) 862-1740
MACHINERY@KBCTOOLS.COM
WWW.KBCTOOLSANDMACHINERY.COM**



PARTS REQUEST FORM

YOUR COMPANY NAME: _____

STATE/PROVINCE _____

YOUR NAME _____

PHONE # + EXT _____

FAX # _____

MACHINE INFO: _____

MAKE/MANUFACTURER _____

MODEL NUMBER _____

YEAR MADE _____

SERIAL# _____

PARTS REQUESTED:

PART#	DESCRIPTION
-------	-------------

_____	_____
-------	-------

_____	_____
-------	-------

_____	_____
-------	-------

_____	_____
-------	-------

_____	_____
-------	-------

_____	_____
-------	-------

_____	_____
-------	-------

PLEASE INCLUDE COPY(S) OF THE PARTS DRAWING FROM THE
MANUAL AND CIRCLE THE PARTS NEEDED

FAX PARTS REQUEST TO (800) 862-1740

E-MAIL PARTS REQUEST TO: machinery@kbctools.com

THANKS; KBC MACHINERY - MICHIGAN

SG-612B

HAND OPERATED
SURFACE GRINDING MACHINE

SERVICE MANUAL

- ACCURACY
- FAST PRODUCTION
- LOW MAINTENANCE

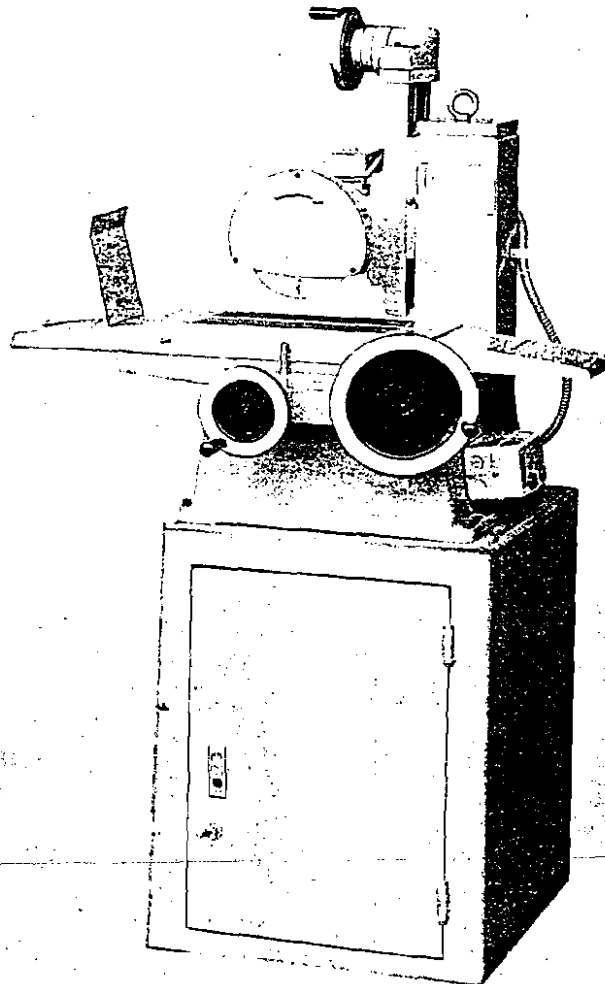

Operating Controls and Set-Up Adjustments
of the
Precision Micromaster Surface Grinding Machine

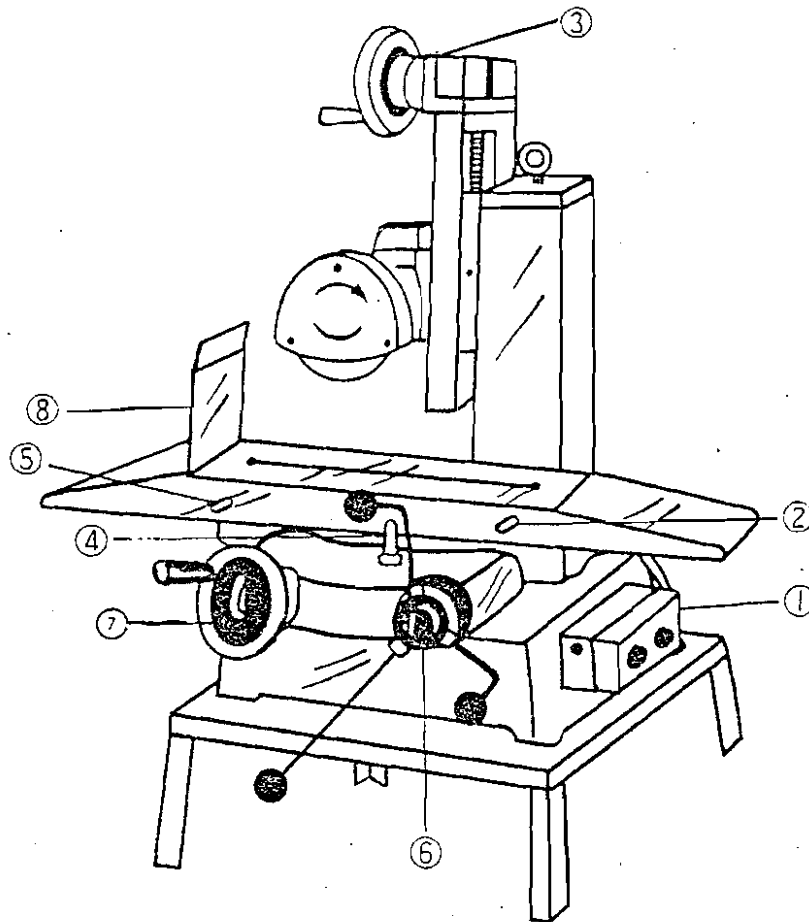

1. Spindle " Start-Stop" Buttons.
2. Table Dog.
3. Vertical Adjustment Handwheel.
4. Table Dog Stop.
5. Table Dog.
6. Table Travel Handwheel.
7. Cross Feed Handwheel.
8. Shield Plate.

Installing or Relocating the Machine

In lifting or moving the machine it is recommended that the rope be rigged as shown in Fig 1. Place wooden blocks or protective material between the rope and the machine wherever the rope is liable to damage any part.

If available, a "fork-lift truck" can be used to move the machine. The lift is located under steel bars positioned in the holes in the base of the machine.

CAUTION: Do not push on the upright when moving the machine unless the rods and strap used in shipping are in place. The upright is a sliding member held on by its own weight and the cross feed screw. Considerable damage can be caused to the cross feed screw if the upright is tilted on its ways.

The machine should be located on a level foundation or floor, a solid vibrationless foundation being essential where the finest finish must be produced. If the machine must be set on a wooden floor, locate it over a beam and on a portion of the floor which is free of vibration. In case the foundation or floor unavoidably transmits vibration to the machine, set the machine on a shock-absorbing pad.

While the machine in position, test the surface of the table both longitudinal and cross with a

precision spirit level and drive a wooden shingle under any corner or corners that may be low. Make sure that all four corners are supported; then tighten the lag screws, test the level of the table surface again in both directions and readjust if necessary.

Connecting to Power Supply. The machine should be connected to the power line and properly grounded. The lines from the power source should be connected to the magnetic starter, mounted on the right side of the machine.

Checking Motor Rotation. Press the magnetic starter "start" and observe the direction of spindle rotation. The spindle should rotate clockwise as seen from the front of the machine. If the direction of rotation is counterclockwise, change two wires at the starter.

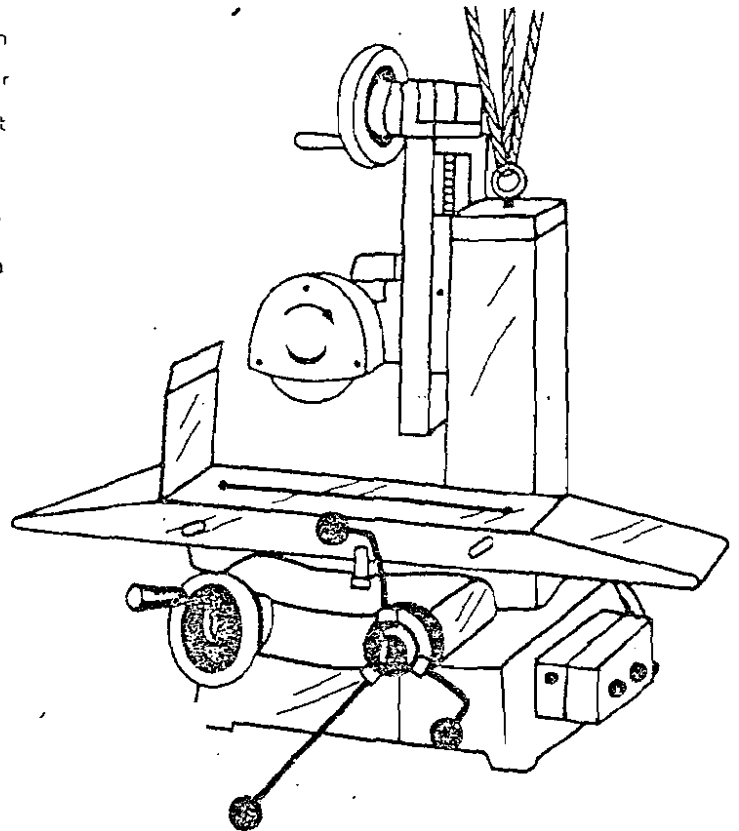

Set-Up Adjustments and Operating Controls

Since the clamp screw merely holds the thrust collar in position and does not govern the closeness of adjustment, there is no reason to use excessive clamping pressure.

For normal surface grinding or when grinding shoulders with the outer face of the wheel, the clamp screw can be released, leaving the thrust springs to take up end play automatically.

Wheel Speed. When the Spindle is driven by a 60 cycle direct drive motor, the full load speed is 3450 R.P.M. using a 7" diameter wheel, ½" thick.

Wheel Guard. The wheel guard is a one-piece unit cover on the front. The cover opens upward and is held closed by four knurled-head screws. All that is required to remove the wheel is to lift the cover.

However, it is necessary to remove the wheel by guard-remove the wheel.

Two clamp screws located on the clamping edge of the wheel guard support can be loosened and the guard tipped either side of horizontal if necessary.

Warning: Always make sure that the guard is securely clamped before starting the machine; and never run a wheel without having the guard and its cover in place.

Care and Use of Grinding Wheels

Selecting the Wheel. In order to produce the desired quality of work in the shortest time real care is necessary in choosing the wheel which is best for the job at hand.

Mounting Wheels. One general-purpose grinding wheel and one wheel sleeve are furnished with the machine. When additional wheels are used, extra wheel sleeves should be procured so that each wheel can be kept on its own sleeve. Thus, in changing from one type of wheel to another, the wheel and sleeve can be changed as a unit and will remain concentric, requiring only a minimum amount of truing.

The wheel should fit easily on the wheel sleeve, yet not loosely, for if it is loose it cannot be centered accurately and will consequently be out of balance. Do not wrap the sleeve with paper etc. to make a wheel fit when the hole is too large. It is

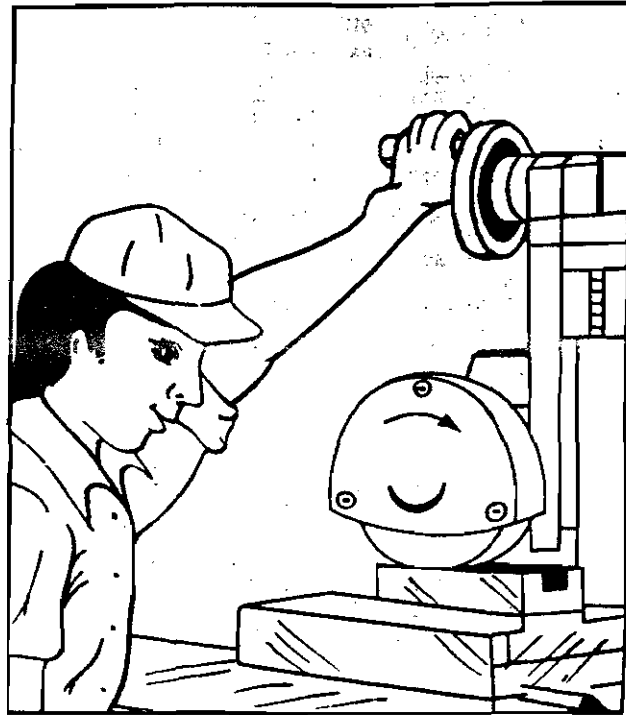

The vertical adjustment hand wheel is shown near the top of the upright

better from all standpoints either to discard such a wheel or rebase the core.

A wheel that fits a trifle tightly may crack if forced on the sleeve. If the hole is only a little under size it can easily be scraped out to fit.

Warning: Before mounting a wheel, hang it in the air on one finger; then lightly tap the edge of the wheel and see if it gives a clear ringing sound. A wheel that does not ring clear is probably cracked and should not be used.

The inner of the two flanges between the wheel is mounted is a part of the wheel sleeve. The outer flange consists of a steel disk or washer which is keyed to the wheel sleeve to keep it from turning and loosening the clamping nut.

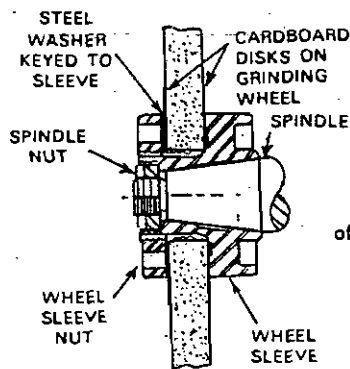

Proper mounting of grinding wheel.

To equalize the clamping pressure, washers of cardboard or rubber should be placed between the wheel and the two flanges. Most wheels of the size used on this machine have a ring of heavy blotting paper on each side, which serves the purpose.

Using the pin wrench furnished, tighten the clamping nut enough to hold the wheel firmly in place on the sleeve. Do not tighten too much, however, as excessive clamping pressure will crack the wheel.

Changing Wheels. In removing a wheel sleeve from the spindle, always use the wheel sleeve puller (furnished with the machine) to avoid any chance of cracking the wheel or damaging the spindle bearings by pounding. Remove the spindle nut (this nut has a left-hand thread the outer member of the wheel sleeve puller into the wheel sleeve and tighten the inner screw against the spindle, thus, loosening the wheel sleeve without harmful jarring.

In putting a wheel on the spindle, examine both the wheel sleeve hole and the spindle end are perfectly clean. Then slip the sleeve onto the spindle, seat it by hand and tighten by means of the clamping nut and wrench.

Balance of Wheel. It is essential that the wheel run perfectly true and without vibration. Grinding wheels are balanced by the manufacturer and, in the case of wheels of the size used on this machine, should not require attention in this respect other than truing. A wheel that runs badly out of balance after

truing should be discarded or returned to the wheel manufacturer—though in cases of necessity the condition may be corrected by digging out part of the wheel beneath the flange and filling with lead as indicated by a test for static balance.

Wheel Truing. A wheel truing fixture is furnished with the machine. The truing diamond (furnished) may be applied to the wheel along any line on the lower half of the wheel circumference, though preferably at the bottom of the wheel as shown. To prevent gouging, the center line of the diamond tool should point slightly the center of the wheel in the direction of movement of the wheel surface.

The wheel should be trued each time it is put on the spindle and whenever it becomes loaded, dull or glazed. Pass the diamond across the wheel with a slow, steady manual cross feed, taking care to avoid any longitudinal movement of the table.

In truing a wheel for rough grinding, take a cut about 0.01m/m deep in one pass of the diamond across the wheel and finish with a similar cut 0.000,25" deep. If the wheel is to be used for finishing grinding, take two 0.01m/m cuts; then take two or three additional cuts removing about 0.000,25" each time, and finally pass the diamond across the wheel once or twice without further advance of the wheel.

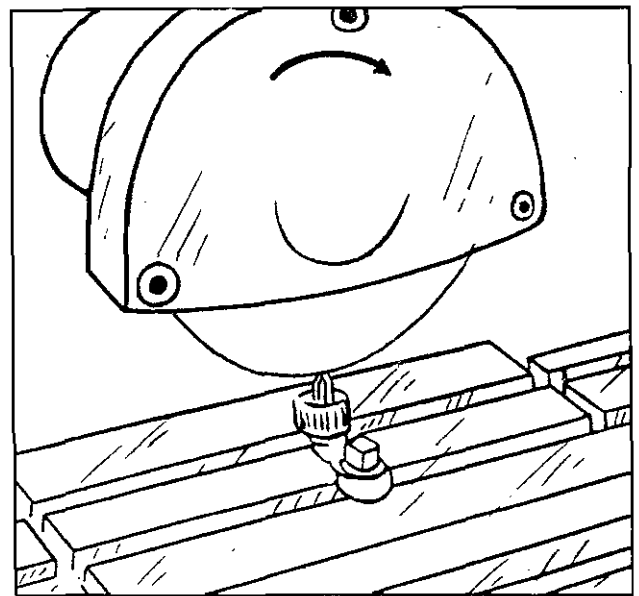

Wheel truing fixture in use.

The figures stated are approximate and under some conditions should be varied somewhat to give desired results.

Typical Operation

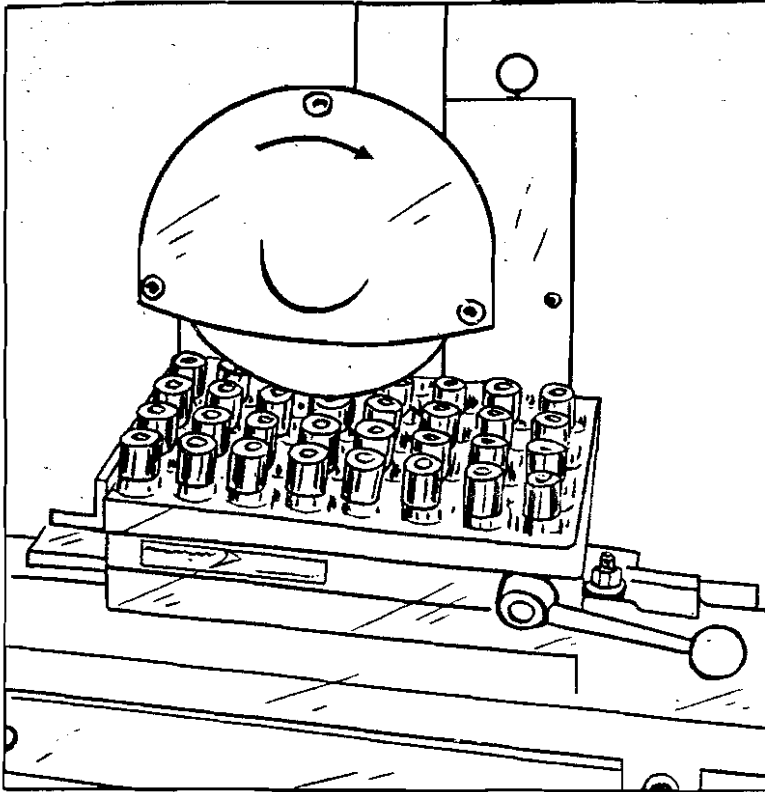

A representative production job grinding the surfaces of thirty-two pieces with one loading of the permanent magnet-type chuck.

Movable wheel slide upright contributes immeasurably to accurate slot grinding.

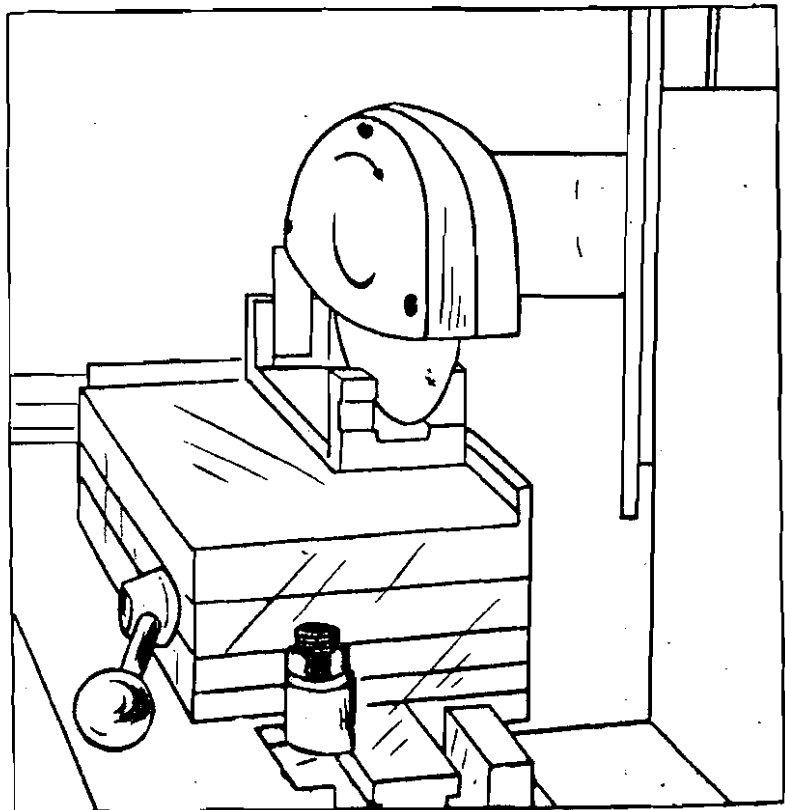

Optional Mechanism and Additional Equipment

(Furnished at Extra Cost)

Various items of additional equipment available as extras are described and illustrated in this chapter. Instructions are also given on their set-up and use.

These extras include Magnetic Chucks and Precision Grinding Vise.

Magnetic Chucks

The Rectangular Model Permanent Magnet Chucks provide a quick, easy means of holding a variety of ferrous work for surface grinding. A 180° movement of the control lever turns the chuck on or off; and since the chuck does not use electric current, it can be left turned on for long as desired without heating.

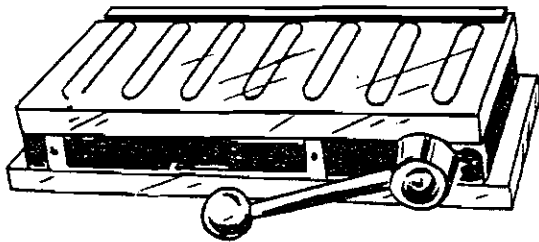

Permanent Magnet Chuck.

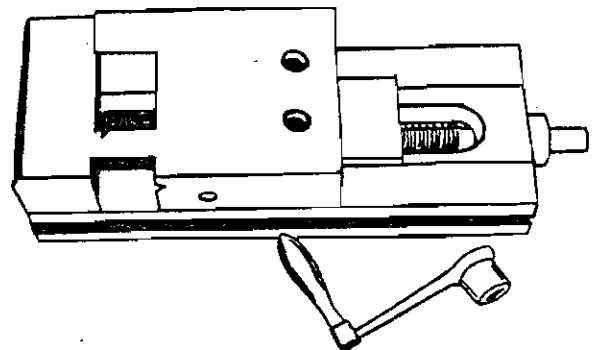

Precision Grinding Vise

For highest accuracy in grinding work parallel, the top surface of the chuck should be ground each time the chuck is mounted on the machine. Be sure that the chuck is turned on before doing this, and remove only the minimum amount of metal required to grind the entire top surface.

The chuck should not be subjected to excessive heat, shocks or blows, and the top should be kept free from pits and scratches. Regrind the top surface occasionally if necessary, as a smooth surface is essential for grinding work parallel.

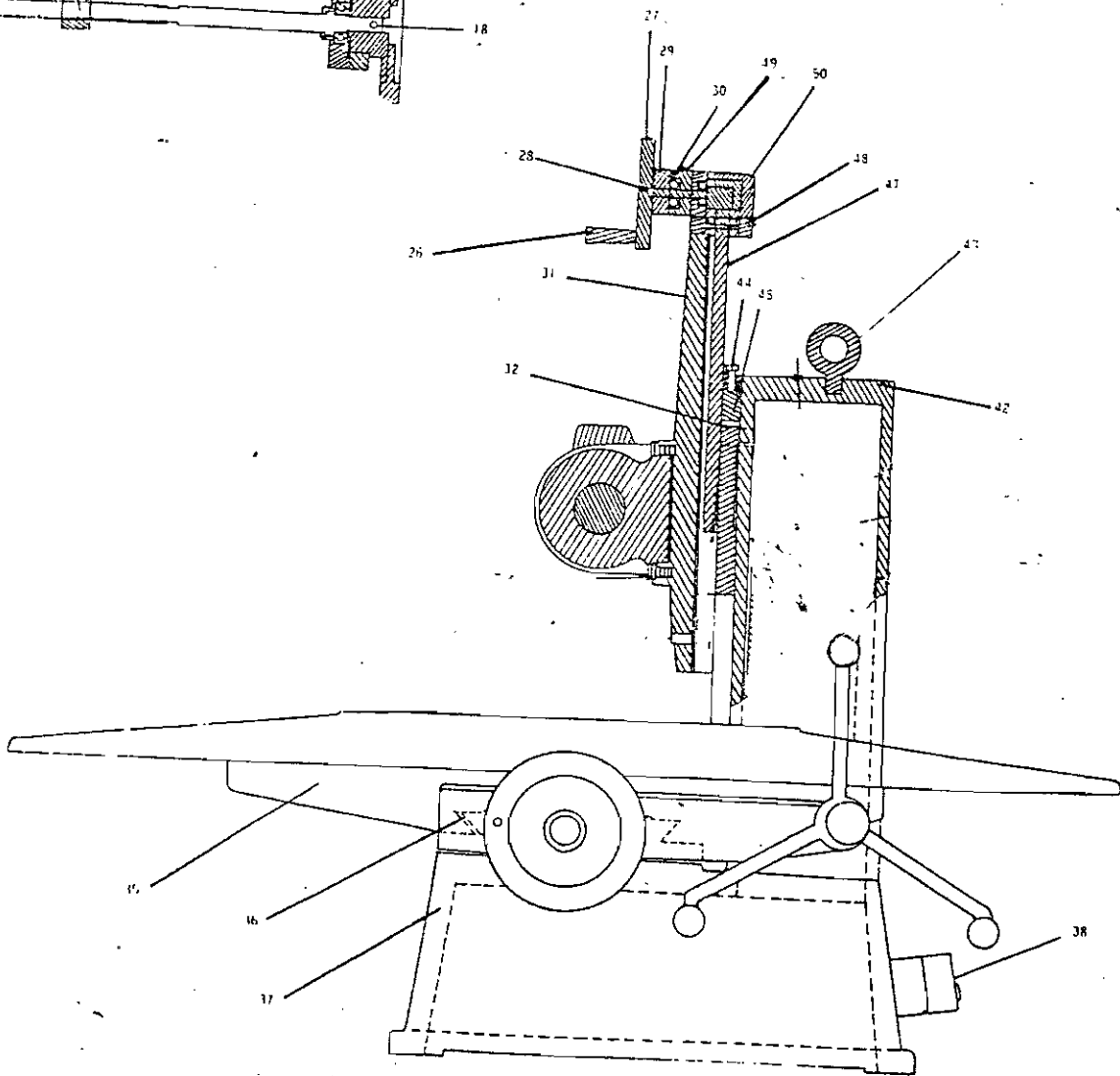
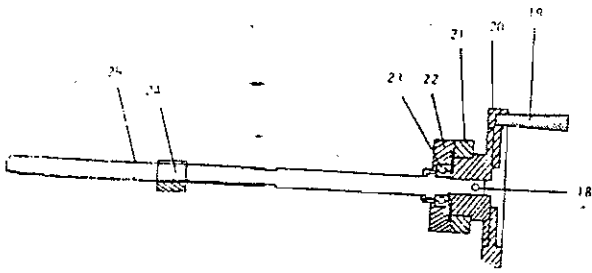
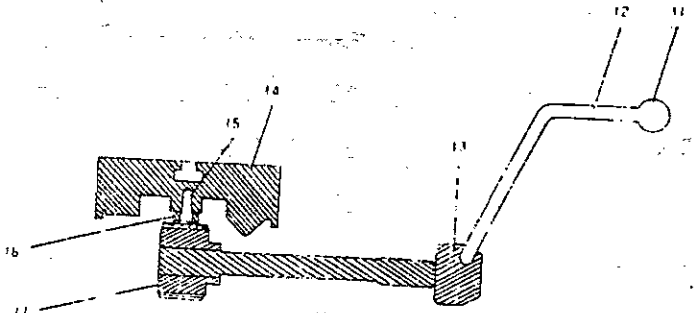
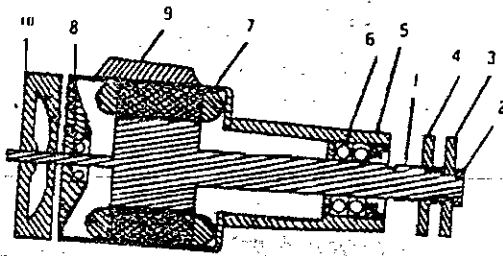

1 GRINDING SPINDLE	30 BEARING
2 FRONT NUT	31 ELEVATING SEAT
3 GRINDWHEEL LOCKING NUT	32 ELEVATING BASE
4 GRINDWHEEL LOCKING BASE	33 LOCKING SCREW
5 FRONT LOCKING NUT	34 WEIGHT BOLT
6 BEARING	35 SADDLE MOUNT
7 GRINDWHEEL BLOCK	36 PRESS BAR
8 BEARING	37 BASE
9 CONNECTION BOX	38 POWER SWITCH
10 MOTOR CASE	39 BALANCE BLOCK
11 HANDLE (PLASTIC)	40 SUSPENSION ROD
12 HANDLE BAR	41 STEEL CHAIN
13 GUIDE ROD	42 BASE
14 WORKING TABLE	43 LIFTING RING
15 HEXAGON SCREW	44 LOCKING SCREW
16 RACK	45 ELEVATING NUT
17 GEAR	46 PULLEY
18 KEY	47 ELEVATING WORM
19 HANDLE	48 GUIDE PLATE
20 HANDWHEEL	49 BEARING BLOCK
21 DIAL	50 GEAR BOX
22 BEARING BLOCK	
23 BEARING	
24 LONGITUDINAL NUT	
25 LONGITUDINAL WORM	
26 HANDLE	
27 HANDWHEEL	
28 KEY	
29 DIAL	