

**MACHINERY DIVISION**

6465 18 MILE ROAD  
STERLING HEIGHTS, MI 48314

**PHONE:**  
(586) 731-3600 • 1-800-860-1740

**FAX:**  
(586) 731-7464 • 1-800-862-1740

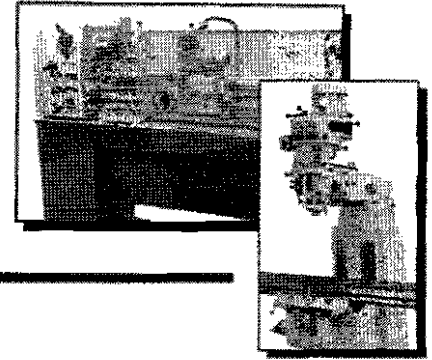

## **MODEL GRIP-1340G LATHE**

**THANK YOU FOR PURCHASING WITH KBC MACHINERY. ALL KBC MACHINES ARE BACKED BY OUR 1 YEAR PARTS REPLACEMENT WARRANTY. WHEN USED AS INTENDED, AND WITH PROPER MAINTENANCE THIS MACHINE WILL PROVIDE YOU WITH YEARS OF TROUBLE-FREE SERVICE. IF YOU NEED PARTS SIMPLY FILL OUT THE PARTS REQUEST FORM, AND FAX OR E-MAIL YOUR REQUEST. ALL OTHER QUESTIONS PLEASE CONTACT US @ :**

**KBC MACHINERY  
6465 18 MILE ROAD  
STERLING HEIGHTS, MI 48314  
PH (800) 860-1740  
FAX (800) 862-1740  
[MACHINERY@KBCTOOLS.COM](mailto:MACHINERY@KBCTOOLS.COM)  
[WWW.KBCTOOLSANDMACHINERY.COM](http://WWW.KBCTOOLSANDMACHINERY.COM)**



# PARTS REQUEST FORM

YOUR COMPANY NAME: \_\_\_\_\_

STATE/PROVINCE \_\_\_\_\_

YOUR NAME \_\_\_\_\_

PHONE # + EXT \_\_\_\_\_

FAX # \_\_\_\_\_

MACHINE INFO: \_\_\_\_\_

MAKE/MANUFACTURER \_\_\_\_\_

MODEL NUMBER \_\_\_\_\_

YEAR MADE \_\_\_\_\_

SERIAL# \_\_\_\_\_

PARTS REQUESTED:

PART#	DESCRIPTION
-------	-------------

_____	_____
-------	-------

_____	_____
-------	-------

_____	_____
-------	-------

_____	_____
-------	-------

_____	_____
-------	-------

_____	_____
-------	-------

_____	_____
-------	-------

PLEASE INCLUDE COPY(S) OF THE PARTS DRAWING FROM THE  
MANUAL AND CIRCLE THE PARTS NEEDED

FAX PARTS REQUEST TO (800) 862-1740

E-MAIL PARTS REQUEST TO: [machinery@kbctools.com](mailto:machinery@kbctools.com)

THANKS; KBC MACHINERY - MICHIGAN

# GRIP-1340G

## OPERATION MANUAL & PARTS LIST

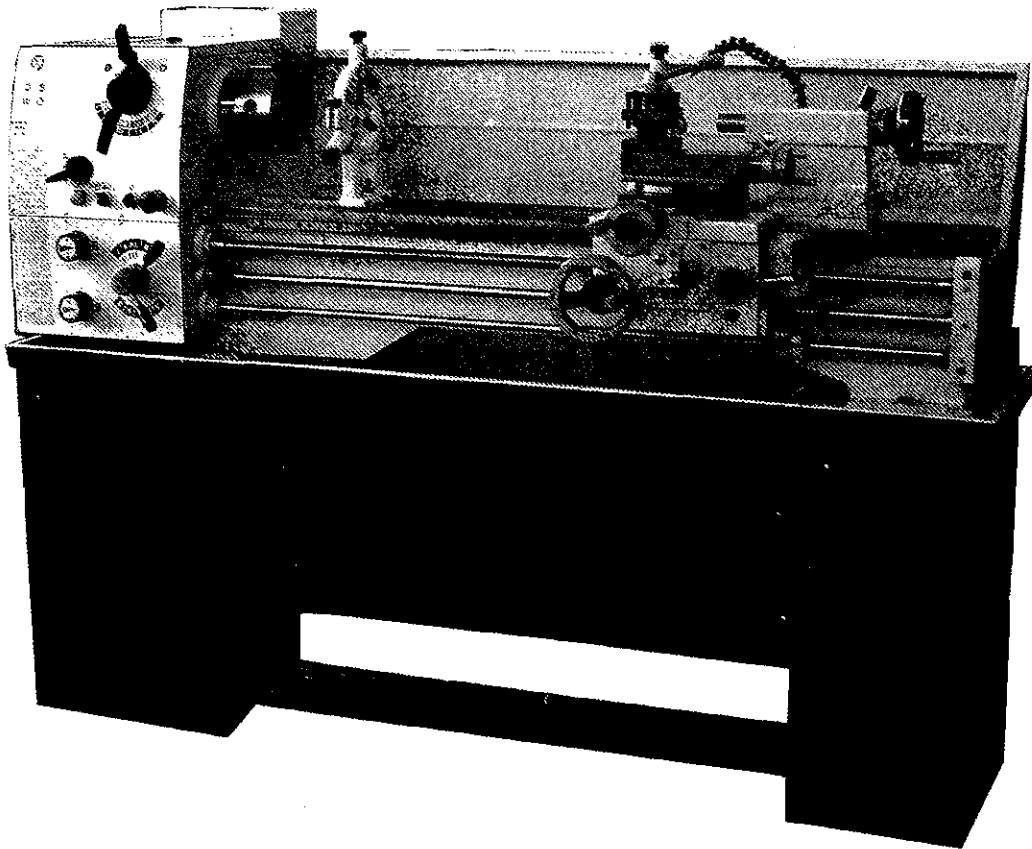

MODEL: 1330, 1340, 1430, 1440

## CONTENTS

<b>Preface</b> .....	<b>2</b>
<b>1. Safety rules for lathes</b> .....	<b>3</b>
<b>2. Machine specification (13")</b> .....	<b>4</b>
<b>Machine specification (14")</b> .....	<b>4-1</b>
<b>3. Constructional indication</b> .....	<b>5</b>
<b>4. Unpacking and installation</b> .....	<b>6</b>
4-1. Unpacking.....	6
4-2. Cleaning.....	6
4-3. Installation.....	6
<b>5. Lubrication</b> .....	<b>7</b>
5-1. Headstock.....	7
5-2. Gearbox.....	7
5-3. Apron.....	7
5-4. Change gears.....	7
5-5. Others parts.....	7
<b>6. Test running</b> .....	<b>8</b>
6-1. Operation Symbols.....	8
6-2. Spindle Speed Control.....	9
<b>7. Thread and feed selection</b> .....	<b>10</b>
7-1. Thread and feed selection.....	10
7-2. Feed and thread tables.....	11
7-3. Threading dial indicator.....	13
<b>8. Electric circuit control</b> .....	<b>14</b>
<b>9. Chucks and chuck mounting</b> .....	<b>16</b>
<b>10. Maintenance and servicing</b> .....	<b>17</b>
10-1. Lathe alignment.....	17
10-2. Saddle strip.....	17
10-3. Cross slide.....	18
10-4. Compound rest.....	18
10-5. Cross slide nut.....	19
10-6. Tail stock bed clamp.....	19
<b>11. Bed Assembly</b> .....	<b>20</b>
<b>12. Headstock Assembly</b> .....	<b>20</b>
<b>13. Gearbox control</b> .....	<b>30</b>
<b>14. Apron (L.H.)</b> .....	<b>36</b>
<b>15. Cross Slide &amp; Compound</b> .....	<b>41</b>
<b>16. Tailstock Assembly</b> .....	<b>45</b>
<b>17. Center Test</b> .....	<b>48</b>

## **PREFACE**

For an efficient and appropriate way of utilization, also for extending the machine's life, all the operators are requested to carefully read the instruction of this Manual before start to operate.

Most of the operators think, according to their own experience, they can handle the machine appropriately and hopeful to neglect what so important items in this booklet. Anyhow, we may say, as per previous experiencing, that many of the breakdowns are resulted from ignoring the instructions of the Manual. Although you have our one-year's warranty for the damage caused by the defect of the machine, either in material or functional, we will not take any responsibility for any damages arise out of improper operation.

In the mean time, besides specification, operator should also thoroughly and deeply acknowledge the character, function and maintenance of this machine before starting.

Generally, in addition to the description stated in coming chapter, you are requested to notice the following points:

1. Never install the machine in the place where the sun shines directly or where the radiation of heat can reach for avoiding from affecting the accuracy of the machine.
2. Use only the recommended lubrication oil.
3. Clean the machine every time when finish working, or a cover will be a plus to prevent the dust.
4. Try to get rid of chips or dusts especially in the grooves of the machine. Keep it as clean as possible or it may be scratched.
5. Whenever the grooves of the machine damaged by falling in extra articles, don't ever try to move Apron. It needs to be repaired to resume its work.

Hope this Operation Manual can be of great assistance and provide you more convenience when operating. The content of this Manual is the best solution derived from our long terms of manufacturing and operating experience. We wish to service you always with an policy of upgrading quality and a conviction in pursuit of perfection.

## 1. SAFETY RULES FOR LATHES

Safety is a combination of operator common sense and alertness at all times when lathe is being used. Study these safety rules and general safety rules before operating and retain for future use.

1. Wear eye protection.
2. Never attempt any operation or adjustment if procedure is not understood.
3. Keep fingers away from revolving parts and cutting tools while in operation.
4. Never force cutting action.
5. Never perform an abnormal or little used operation without study and use of adequate blocks, jigs stops, fixtures ECT.
6. Use of shop manual such as "machinery's handbook" or similar is recommended for cutting speeds feeds and operation detail.
7. Do not remove drive cover while machine is in operation. Make sure it is always closed.
8. Always remove chuck key, even when machine is not in operation.
9. Do not attempt to adjust or remove tools when in operation.
10. Always keep cutters sharp.
11. Never use in an explosive atmosphere or where a spark could ignite a fire.
12. Always use identical replacement parts when servicing.

**Warning:** Do allow familiarity (Gained from frequent use of your lathe) to become commonplace. A careless fraction of a second can allow for severe injury.

## 2. MACHINE SPECIFICATION

Bench lathe are especially suitable for machining, tool tooms and repairing working shops to machine shafts, spindle, sleeves, and disc work piece of middle or small types. They can also be used to cut imperial, dametral and module thread, and with compact construction and reasonable composition, they can cut very well. They are easy and reliable to operate, convenient to repair high in efficiency, and low noise.

### Technical specification

Swing over bed.....	330mm
Swing over support.....	198mm
Swing over gap.....	476mm
Center height.....	166mm
Distance between centers.....	750mm/1000mm
Bed width.....	187mm
Bed height.....	290mm
Motor output.....	1.5KW
Voltage.....	220V or 380V
Spindle bore.....	38mm
Cam lock system.....	D1-4
Spindle speed.....	70-2000r.p.m
Spindle taper.....	MT No.5
Cross slide travel.....	160mm
Compound slide travel.....	68mm
Leadscrew diameter.....	22mm
Feed rod diameter.....	19mm
Cutting tool (Max. section).....	16mm×16mm
Imperial thread.....	4-56T.P.I
Metric thread.....	0.4-7mm
Diametric pitch thread.....	8-120D.P
Module thread.....	0.2-3.5M.P
Longitudinal feed.....	0.082-2.713mm/rev
Cross-feed.....	0.022-0.933mm/rev
Tailstock quill diameter & taper...	32mm No.2 Morse or No.3
Weights (Approx.).....	750mm                      1000m
	NW 460kgf                      495kgf
	GW 555kgf                      585kgf

### 3. Constructional Indication

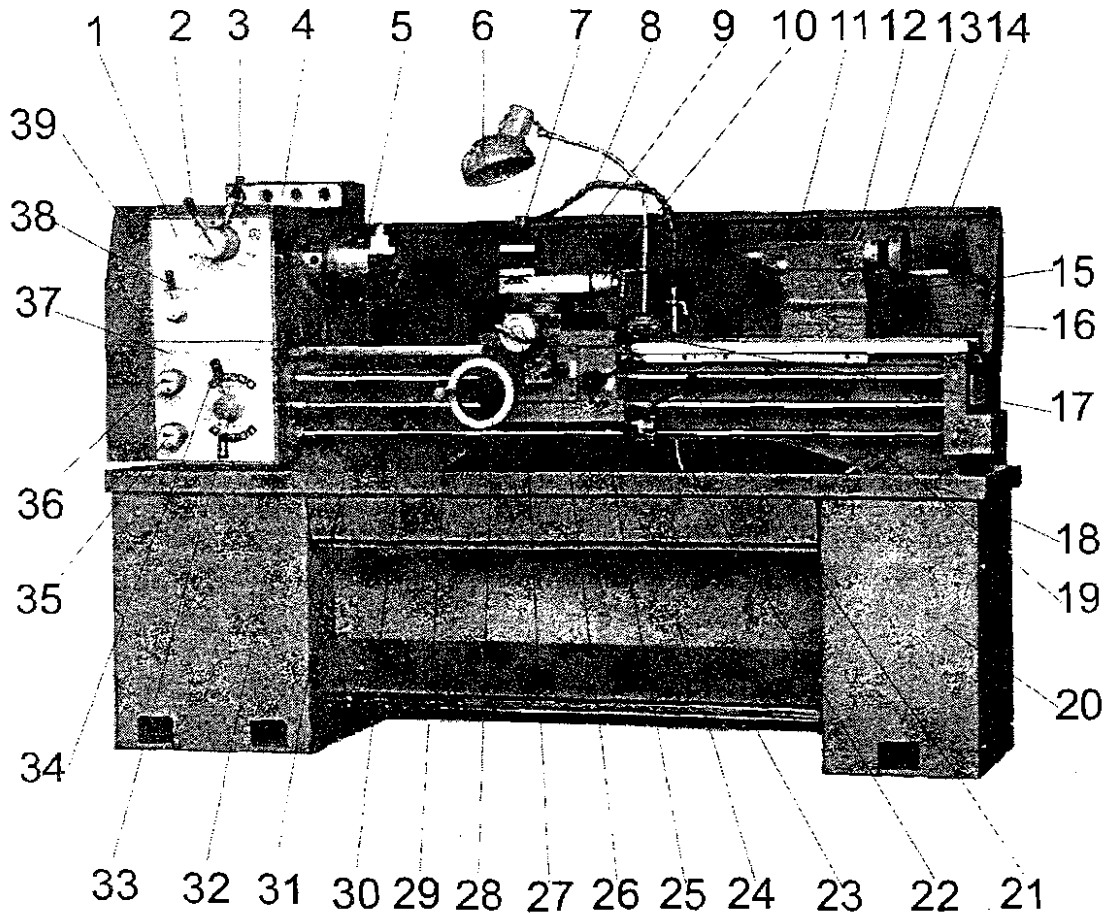

- |                                 |                                      |
|---------------------------------|--------------------------------------|
| 1. Headstock                    | 21. Spindle Control Lever            |
| 2. Speed Selector               | 22. Thread Cutting Engagement Lever  |
| 3. Speed Selector               | 23. Foot-Brake                       |
| 4. Eclectic Control Box         | 24. Front Plate                      |
| 5. Spindle With Three-Jaw Chuck | 25. Apron                            |
| 6. Work Lamp                    | 26. Feed Axis Selector               |
| 7. Tool Support                 | 27. Cross Traverse Handle            |
| 8. Coolant System               | 28. Longitudinal Traverse Hand wheel |
| 9. Compound Rest Lock           | 29. Control Rod                      |
| 10. Compound Rest Handle        | 30. Feed Rod                         |
| 11. Quill Clamp Lever           | 31. Lead screw                       |
| 12. Tailstock Clamp Lever       | 32. Left Mountain Feet               |
| 13. Quill Traverse Handle       | 33. Feed Selector                    |
| 14. Guard Plate                 | 34. Feed Selector                    |
| 15. Tailstock                   | 35. Feed Box Selector                |
| 16. Tailstock Set-Over Screw    | 36. Feed Box Selector                |
| 17. Worktable                   | 37. Gear Box                         |
| 18. Chip Tray                   | 38. Feed Direction Selector          |
| 19. Bed                         | 39. Gear Box Cover                   |
| 20. Right Mountain Feet         |                                      |

## 4. UNPACKING AND INSTALLATION

### 4-1. Unpacking

Unload the machine with a tackle, using clamping plates and eyebolts. Keep the machine in balance by moving the tailstock and the bed slide to the right. Avoid using sling chains as they could damage to feed rod and leadscrew. Lift the lathe carefully and place it softly into the floor or workbench.

### 4-2. Cleaning

Before taking the machine into operation, using kerosene (paraffin) or white spirit to remove the anti-corrosive coating or grease from all slideways and gear train. Don't use lacquer thinner or other caustic solvents. Oil all bright machine surfaces immediately after cleaning. Use heavy oil or grease on the change gears.

### 4-3. Installation

Place the lathe on a solid foundation. A concrete floor is the best base for the machine. (If necessary, use an under frame operational). Make sure there is

sufficient area around the lathe for easy work and maintenance. Use a precision level on the bedways to make further adjustment for level condition, then tighten the foundation bolts evenly and finally recheck for level condition.

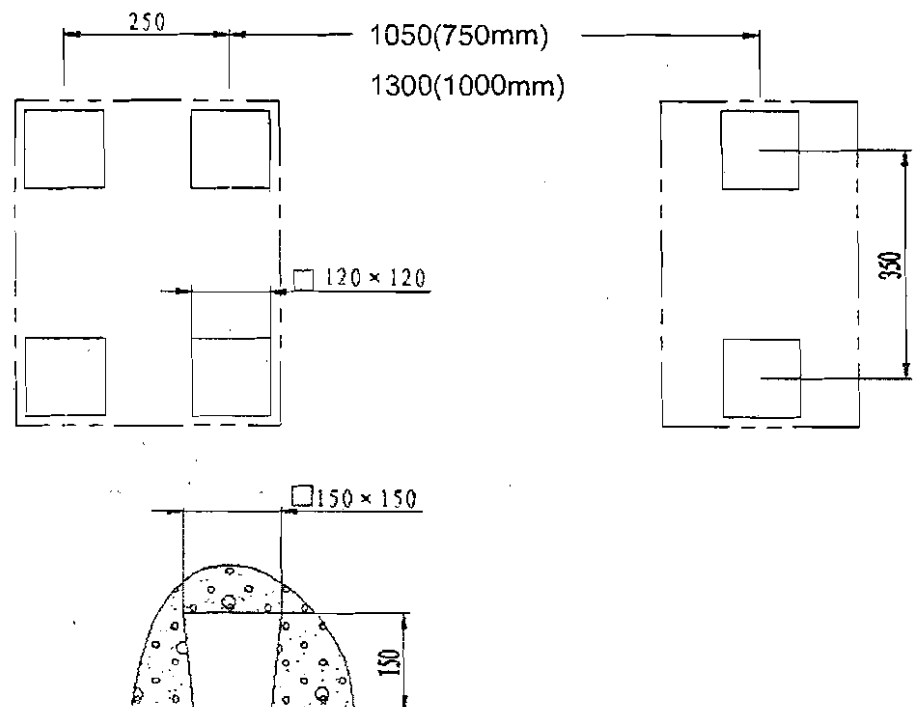

## **5. LUBRICATION**

Before putting the lathe into operation, make the following lubrication check.

### **5-1. Headstock**

The bearing of the headstock turns in an oil bath. Ensure that the oil level reaches three quarters of the oil gauge glass.

For exchanging the oil, remove the end cover and the change gears with swing frame. Drain off the oil by removing the drain plug on the bottom of the headstock. To fill, take off the headstock cover.

Check the oil level regularly. The first oil change should be made after 3 month, then change it once a year.

### **5-2. Gearbox**

Remove the end cover to expose the filling plug. Through it the Shell Tellus 32 is filled to the oil level in the oil gauge glass regularly. The first oil change should be made after three months, then change it once a year.

### **5-3. Apron**

The oil bath is filled with Shell Tellus 32 through the filling plug on the right side of the apron. Check the oil level in the oil gauge glass on the front regular. The first oil change should be made after three months, then change it once a year.

For exchanging the oil, drain away oil by taking off the drain plug on the bottom of the apron.

### **5-4. Change gears**









Lubricate the change gears with thick machine oil or grease once a month.

### **5-5. Other parts**

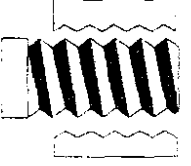
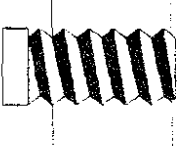
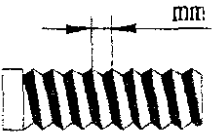
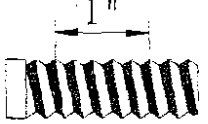
There are other lubricating points on the input shaft bracket of the gearbox, the handwheel on the apron, the longitudinal and cross slide, the thread dial indicator, the tailstock and the bracket, use the grease gun to put a few drops of oil from time to time. Lubricate the apron worm and worm gear, half nut and leadscrew twice a month. Apply a light oil film to the bed way and all other bright parts like the tailstock quill, feed rod ECT. once a day.

## 6. TEST RUNNING

### 6-1. Operation symbols

	<p>Electrical control (Danger)</p>		<p>Coolant</p>
	<p>Half nut opened</p>		<p>Half nut closed</p>
	<p>Metric thread</p>		<p>Imperial thread</p>
		<p>Right-hand thread and longitudinal feed toward the headstock side (left figure)</p> <p>Left-hand thread and longitudinal feed toward the headstock side (right figure)</p>	
	<p>Longitudinal feed engaged (upward). Both Longitudinal feed disengaged (central). Cross feed engaged (downward)</p>	<p><b>OIL</b></p>	<p>Oil inlet (hole)</p>
			<p>Don't change speed while is running</p>
	<p>Module pitch thread</p>		<p>Diametric pitch thread</p>

## **6-2. Spindle speed control**

### **A. Identification before operation**

Ensure that lubrication has been carried out as described before.

When the main spindle is rotating. The gearbox and feed axis of the bedslides are put into operation. The forward/reverse switch (21) should be on neutral. The feed axis selector (26) and feed/thread selector handle (22) are in disengaged position. Under these circumstances, both the longitudinal traverse handwheel and cross traverse handle (27) can be operated by hand.

### **B. Main spindle rotation**

The main spindle rotation is selected by forward/reverse switch.

### **C. Main spindle speed**

The speed of the main spindle is selecting by (high/low) speed selector (3) and 4 steps speed selector (2). For both high and low speed, there are 4 different positions. For correct speed, please refer to the speed chart. When selector (3) is on "high", we can get the four speeds, according to the graph.

Never change the speed before the motor has stopped completely!

Adjusting the speed can be assisted by turn the main spindle by hand.

### **D. Running-in**

Running in should be done at lowest possible spindle speed. Let the machine to run at lowest speed for about twenty minutes, and then check for irregularities. If everything seems in order, gradually increase the speed.

### **E. Operation**

Use only high peripheral speed type chucks.

The maximum spindle speed for chuck plate of 254mm diameter should not be more than 1255r.p.m. When thread cutting or auto feeding are not in use, the feed/thread selector should be in neutral position, so as to ensure disengagement of the leadscrew and the feed rod. To avoid unnecessary wear, the thread dial indicator should be out of mesh with the leadscrew.

## **7. THREAD AND FEED SELECTION**

### **7-1. Thread and feed selection**

All threads and feeds are indicated on the tables fitted on the front and top of the gearbox. They are selected with the feed selector handle on the gearbox.

#### **A. Manual operation**

The carriage is moved by the handwheel (28), the cross slide by handwheel (27) and the compound rest by handwheel (10). The slide can anchor by turning the lock bolts on the top and the slide of the slide.

#### **B. Feed and thread tables**

Longitudinal and cross feed table. Metric and imperial thread table.

#### **C. Automatic feed operation**

Firstly, engage the 40T change gear at the transmission shaft and the 127T intermediate gear with feed direction selector (38), next, set the feed/thread selector (34) to the left hand position and position one lever (33) at any of the 1-8 hole, the other at any of A-E holes, thus the feed rod will rotate. If selector (26) is pushed upward, a longitudinal feed can be obtained. If pushing downward, across feed will be obtained.

#### **D. Thread cutting operation**

The direction of thread cutting is controlling by feed director (38). By operation feed selector handle and feed/ thread selector handle (34) according to thread pitch, the leadscrew rotate. Operate downward the thread cutting engagement lever (22), it should be engaged with leadscrew, thus the longitudinal travel of thread cutting feed.

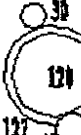

7-2. Feed and thread tables

Longitudinal and cross feed table for metric leadscrew.

	FEED ROD: 2.5mm						FEED ROD: 2.5mm				
	U	T	S	V	R		U	T	S	V	R
PAC	1.142 0.309	1.015 0.275	0.914 0.248	0.762 0.206	0.653 0.177	PAC	2.713 0.933	2.412 0.829	2.171 0.746	1.809 0.622	1.551 0.533
PBC	0.571 0.155	0.508 0.138	0.457 0.123	0.381 0.103	0.326 0.089	PBC	1.357 0.466	1.206 0.414	1.085 0.373	0.904 0.311	0.775 0.266
PAD	0.286 0.077	0.254 0.068	0.228 0.062	0.190 0.052	0.163 0.044	PAD	0.678 0.233	0.603 0.207	0.543 0.187	0.452 0.155	0.388 0.133
PBD	0.143 0.039	0.127 0.035	0.114 0.031	0.096 0.026	0.082 0.022	PBD	0.339 0.116	0.302 0.103	0.271 0.093	0.226 0.078	0.194 0.067

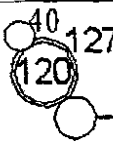
Thread table for metric leadscrew.

	PITCH										T.P.I.							
	M	L	K	L	N	K	J	N	J		N	M	M	M	M	M	M	M
AC	3.2	3.6	4.0	4.5	4.8	5.0	5.6	6.0	7.0	AC	4	4 <sup>1</sup> / <sub>2</sub>	5	5 <sup>1</sup> / <sub>2</sub>	5 <sup>3</sup> / <sub>4</sub>	6	6 <sup>1</sup> / <sub>2</sub>	7
BC	1.6	1.8	2.0	2.25	2.4	2.5	2.8	3.0	3.5	BC	8	9	10	11	11 <sup>1</sup> / <sub>2</sub>	12	13	14
AD	0.8	0.9	1.0		1.2	1.25	1.4	1.5	1.75	AD	16	18	20	22	23	24	26	28
BD	0.4	0.45	0.5		0.6		0.7	0.75		BD	32	36	40	44	46	48	52	56

	MODULE										D.P							
	M	L	K	L	N	K	J	N	J		N	M	M	M	M	M	M	M
AC	1.6	1.8	2.0	2.25	2.4	2.5	2.8	3.0	3.5	AC	8	9	10	11	12	13	14	15
BC	0.8	0.9	1.0		1.2	1.25	1.4	1.5	1.75	BC	16	18	20	22	24	26	28	30
AD	0.4	0.45	0.5		0.6		0.7	0.75		AD	32	36	40	44	48	52	56	60
BD	0.2		0.25		0.3		0.35			BD	64	72	80	88	96	104	112	120

Longitudinal and cross feed table for imperial leadscrew.

30 85 100	FEED ROD: 8T. P. I					30 120 127	FEED ROD: 8T. P. I				
	mm						mm				
	U	T	S	V	R		U	T	S	V	R
PAC	1.142 0.393	1.015 0.349	0.914 0.314	0.782 0.262	0.653 0.224	PAC	2.713 0.933	2.412 0.829	2.171 0.746	1.909 0.622	1.551 0.533
PBC	0.571 0.196	0.508 0.174	0.457 0.157	0.381 0.131	0.326 0.112	PBC	1.357 0.466	1.206 0.414	1.085 0.373	0.904 0.311	0.775 0.266
PAD	0.286 0.098	0.254 0.087	0.228 0.079	0.190 0.065	0.163 0.056	PAD	0.876 0.233	0.603 0.207	0.543 0.187	0.452 0.155	0.388 0.133
PBD	0.143 0.048	0.127 0.044	0.114 0.039	0.096 0.033	0.082 0.028	PBD	0.338 0.116	0.302 0.103	0.271 0.093	0.226 0.078	0.194 0.067

Thread table for imperial leadscrew.

40 120 60	PITCH									40 127	T.P.I							
	mm										INCH							
	M	L	K	L	N	K	J	N	J		N	M	M	M	M	M	M	M
S	S	S	U	S	U	S	U	U	V	T	S	S	S	V	S	R		
AC	3.2	3.6	4.0	4.5	4.8	5.0	5.6	6.0	7.0	AC	4	4 <sup>1</sup> / <sub>2</sub>	5	5 <sup>1</sup> / <sub>2</sub>	6	6 <sup>1</sup> / <sub>2</sub>	7	
BC	1.6	1.8	2.0	2.25	2.4	2.5	2.8	3.0	3.5	BC	8	9	10	11	11 <sup>1</sup> / <sub>2</sub>	12	13	14
AD	0.8	0.9	1.0		1.2	1.25	1.4	1.5	1.75	AD	16	18	20	22	23	24	26	28
BD	0.4	0.45	0.5		0.6		0.7	0.75		BD	32	36	40	44	46	48	52	56

44 120 42	MODULE									63 120	D.P							
	M	L	K	L	N	K	J	N	J		N	M	M	M	M	M	M	M
S	S	S	U	S	U	S	U	U	V	T	S	S	S	V	S	R		
AC	1.6	1.8	2.0	2.25	2.4	2.5	2.8	3.0	3.5	AC	8	9	10	11	12	13	14	15
BC	0.8	0.9	1.0		1.2	1.25	1.4	1.5	1.75	BC	16	18	20	22	24	26	28	30
AD	0.4	0.45	0.5		0.6		0.7	0.75		AD	32	36	40	44	48	52	56	60
BD	0.2		0.25		0.3		0.35			BD	64	72	80	88	96	104	112	120

**7-3. Threading dial indicator**

Metric threads on metric lead screw machine.

mm 	INDICATOR TABLE METRIC DIAL GRADUATION		
	28T	30T	32T
	0.40	1,3,5,7,9,11	
0.45	1,7		
0.50	1,3,5,7,9,11		
0.60	1,3,5,7,9,11		
0.70	1,4,7,10		
0.75	1,3,5,7,9,11		
1.00	1,3,5,7,9,11		
1.25	1,3,5,7,9,11		
1.50	1,3,5,7,9,11		
1.75	1,4,7,10		
2.00		1,4,7,10	
2.25	1		
2.50	1,3,5,7,9,11		
2.80	1,7		
3.00	1,3,5,7,9,11		
3.50	1,4,7,10		
4.00		1,4,7,10	
4.50	1,7		
5.00	1,3,5,7,9,11		
5.60	1		
6.00		1,4,7,10	
7.00	1,4,7,10		

Imperial threads on Imperial lead screw machine.

INDICATOR TABLE					
T.P.I	SCALE	T.P.I	SCALE	T.P.I	SCALE
4	1-4	13	1	44	1-4
4 $\frac{1}{2}$	1	14	1.3	46	1.3
4		16	1-8	48	1-8
5	1	18	1.3	52	1-4
5 $\frac{1}{2}$	1	19	1	56	1-8
5	1.3	20	1-4	64	1-8
6 $\frac{1}{2}$	1	22	1.3	72	1-8
7	1	23	1	76	1-4
8	1-8	24	1-8	80	1-8
9	1	26	1.3	88	1-8
9 $\frac{1}{2}$	1	28	1-4	92	1-8
10	1.3	32	1.3	96	1-8
11	1	36	1-4	104	1-8
11 $\frac{1}{2}$	1	38	1.3	112	1-8
12	1-4	40	1-8		

### 8. ELECTRIC CIRCUIT CONTROL

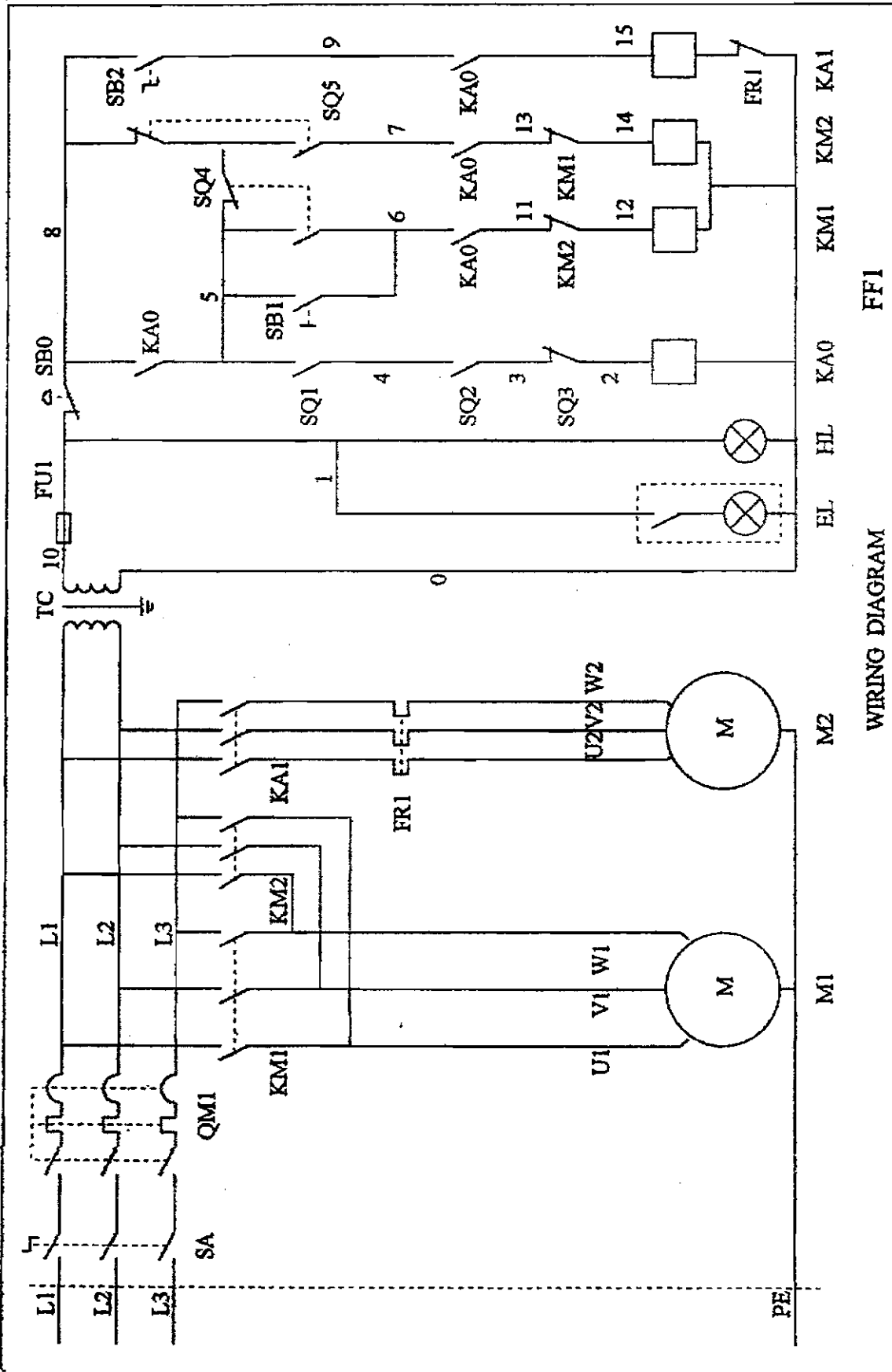

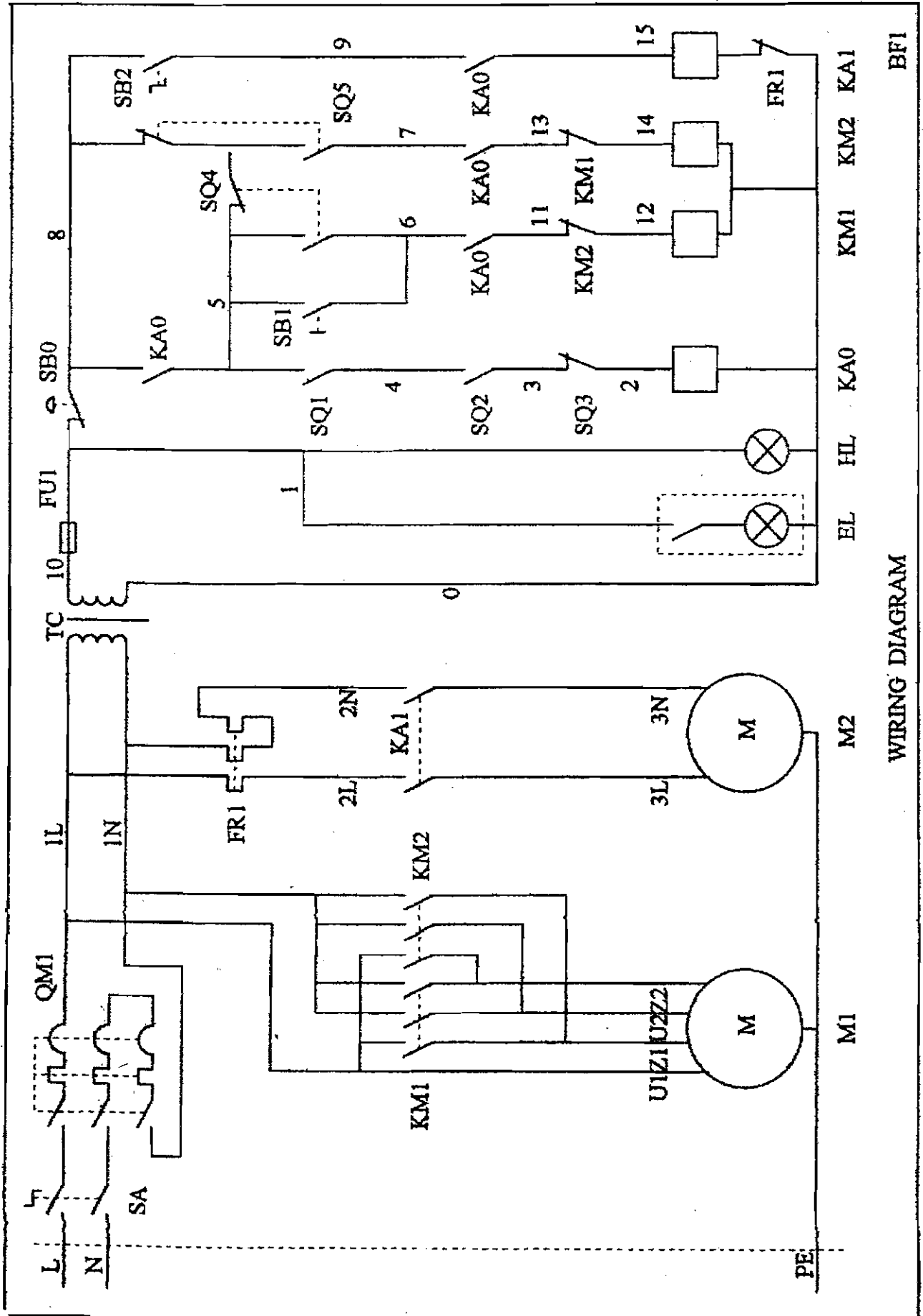

WIRING DIAGRAM

## 9. CHUCKS AND CHUCK MOUNTING

When fitting chucks or faceplates, first ensure that spindle and chuck tapers are scrupulously clean and that all cams lock in the correct positions, see Fig1. It may be necessary when mounting a new chuck to re-set the cam lock studs (A). To do this, remove the cap-head locking screws (B) and set each stud so that the scribed ring (C) is flush with the rear face of the chuck-with the slot lining up with the locking screw hole.

Now mount the chuck or faceplate on the spindle nose and tighten the six cams in turn. When fully tightened, the cam lock line on each cam should be between the two V marks on the spindle nose.

If any of the cams do not tighten fully within these limit marks, remove the chuck or faceplate and re-adjust the stud as indicated in the illustration. Fit and tighten the locking screw (B) at each stud before remounting the chuck for work. A reference mark should be made on each correctly fitted chuck or faceplate to coincide with the reference mark scribed in the spindle nose.

This will assist subsequent remounting. Do Not Interchange Chucks or faceplates between lathes without checking for correct cam locking.

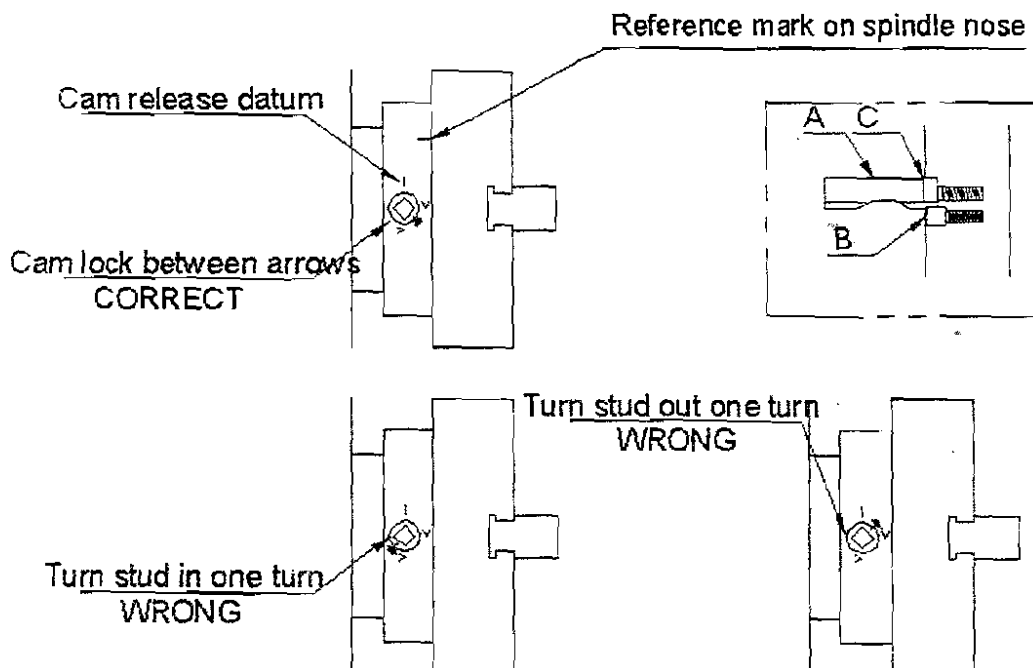

## 10. MAINTENANCES AND SERVICING

### 10-1. Lathe alignment

When the lathe is installed and ready for use, it is recommended to check the machine alignment before commencing work.

Alignment and leveling should be checked regularly to insure continued accuracy.

Adopt this procedure as follow:

Take a steel bar with a diameter of appr.50mm and a length of appr.200mm. Span it in the chuck without using the center. Then cut off a chip over a length of 150mm and measure the difference in A and B.

In order to correct a possible difference, loosen the screw (j) clamping the headstock on the bed. Adjust the headstock with setscrew (s). Repeat the above procedure until all measuring is correct. The lathe will be cutting correctly.

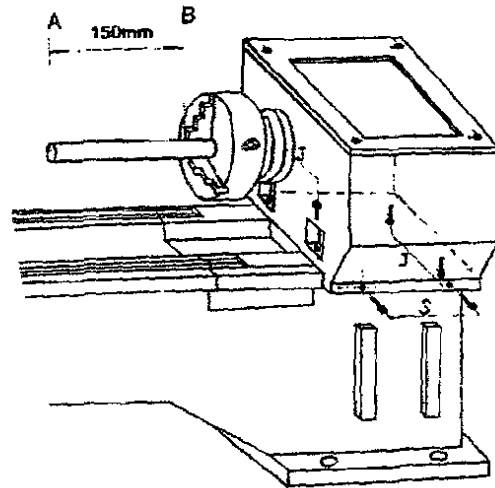

### 10-2. Saddle strip

Wear on the rear saddle gig strip may be accommodated by adjustment of the socket head set screws.

The procedure for adjustment is to first take off the rear splash guard (when fitted), release the hexagon nuts and turn the socket head set screws

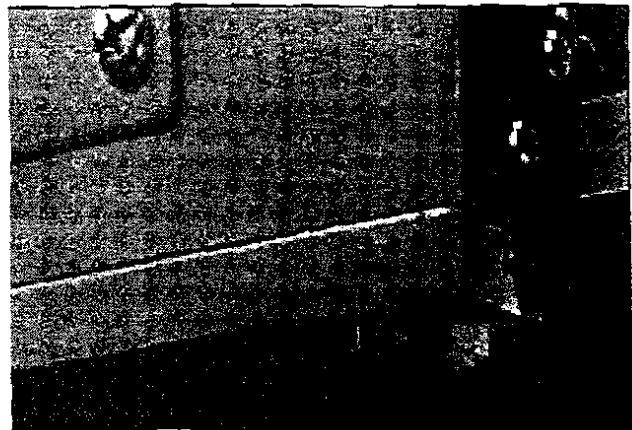

slightly in clockwise and then re-clomp the hexagon nuts. Care should be taken to avoid over adjustment, a 45° turn at the socket head set screw approximately 0.125(0.005") take up in the gib.

### 10-3. Cross slide

Wear on the taper-gib strip may be adjusted for by clockwise rotation of the slotted head screw on the front face of the cross slide. The procedure is to first slacken the similar screw at the rear then retighten this after adjustment to clamp the gib in its new position.

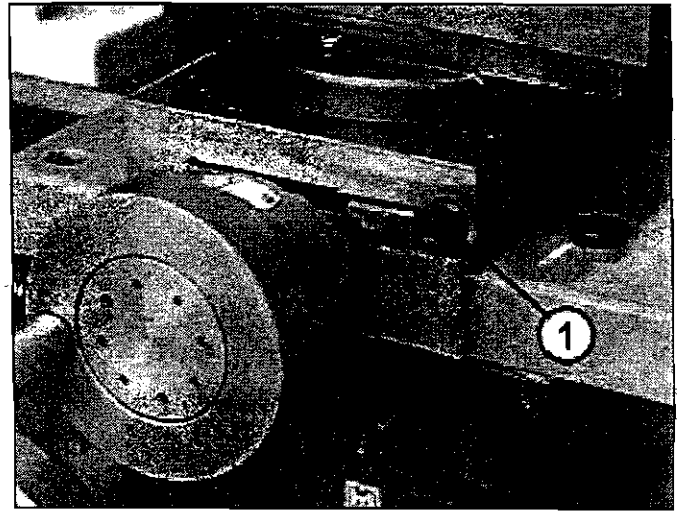

### 10-4. Compound rest

It is the same procedure as cross slide. To take up for wear on the compound rest taper gibe strip can adjust the slotted head screw on the tool post side of the compound rest by clockwise rotation. The procedure is to first slacken the similar screw at the opposite side then re-tighten this after adjustment to clamp the gib in its new position.

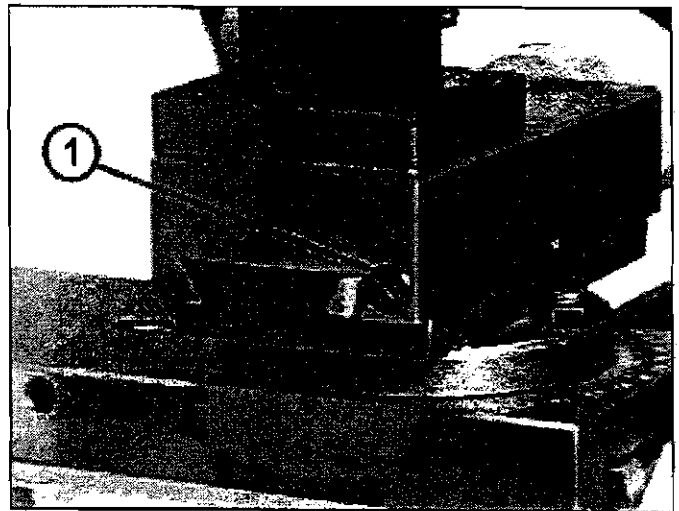

### 10-5. Cross slide nut

Provision is made for the elimination of backlash in the cross slide nut, the procedure for adjustment being as follows:

Take off the dust plate which is mounted on the rear face of saddle groove, turn the cross traverse handle by clockwise to move the cross feed nut until it reaches the end edge of the feed rod. Turn the socket head cap screw in a clockwise direction as required. Care should be taken to avoid over adjustment; a  $45^\circ$  turn at the socket head cap screw represents approximately 0.125mm(0.005") take up of back lash.

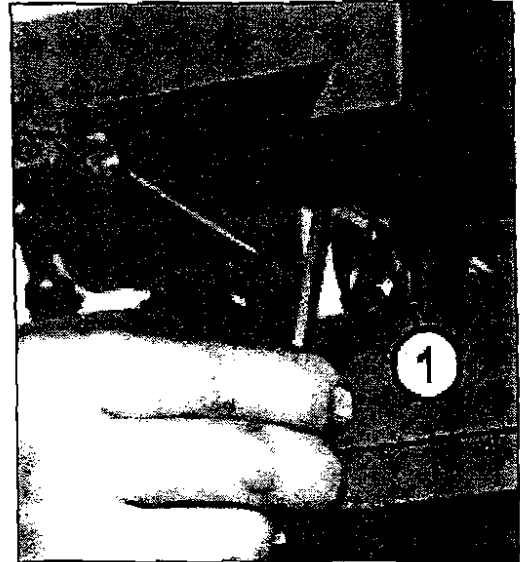

### 10-6. Tail stock bed clamp

The angular lock position of the bed clamp lever is adjusted by means of the self-locking hexagon headed bolt located on the underside of the tailstock and between the bed ways.

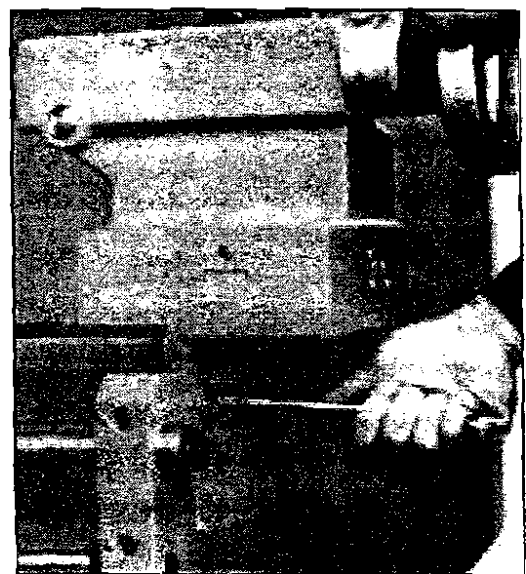

### 11.BED (1/2)

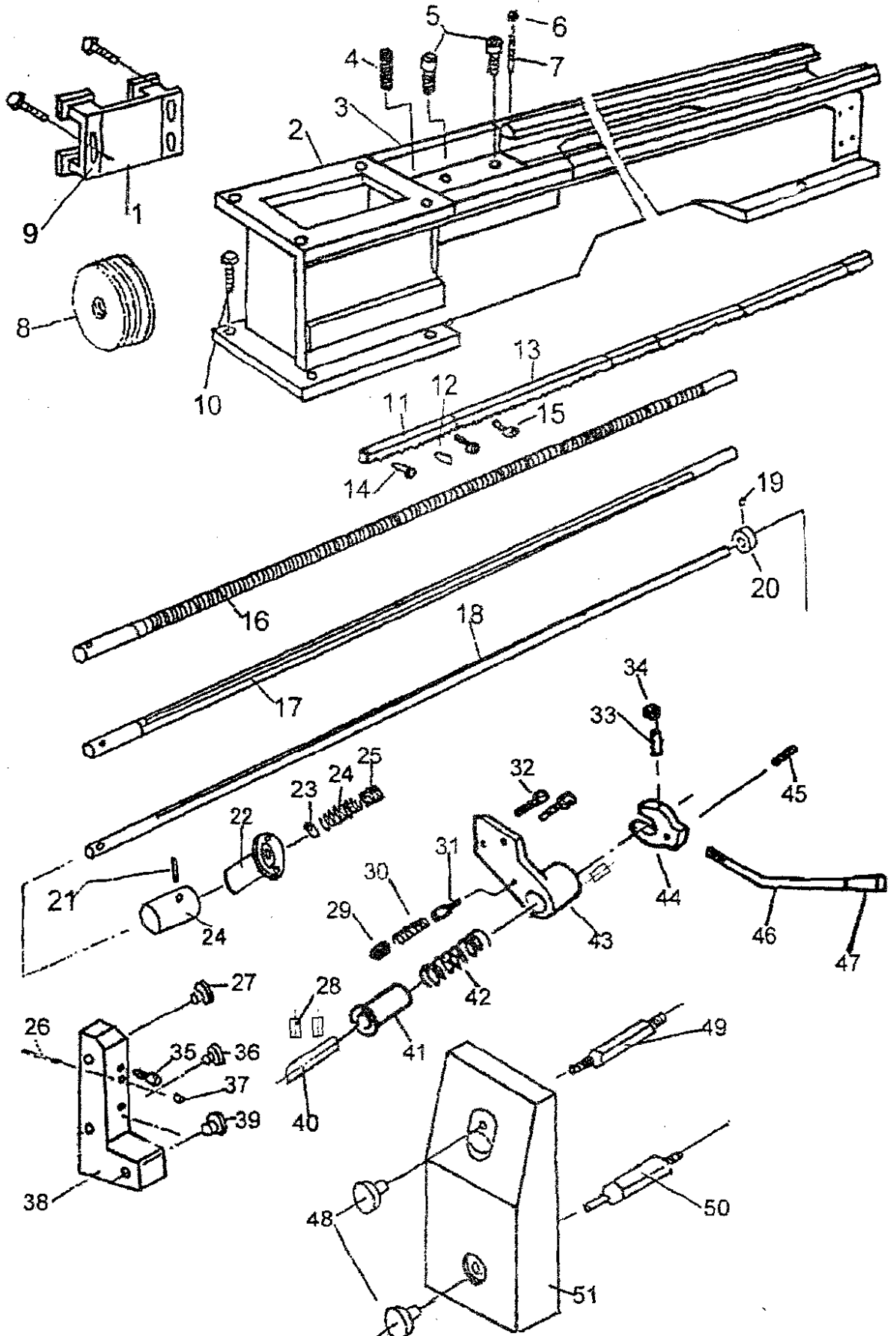

# BED (2/2)

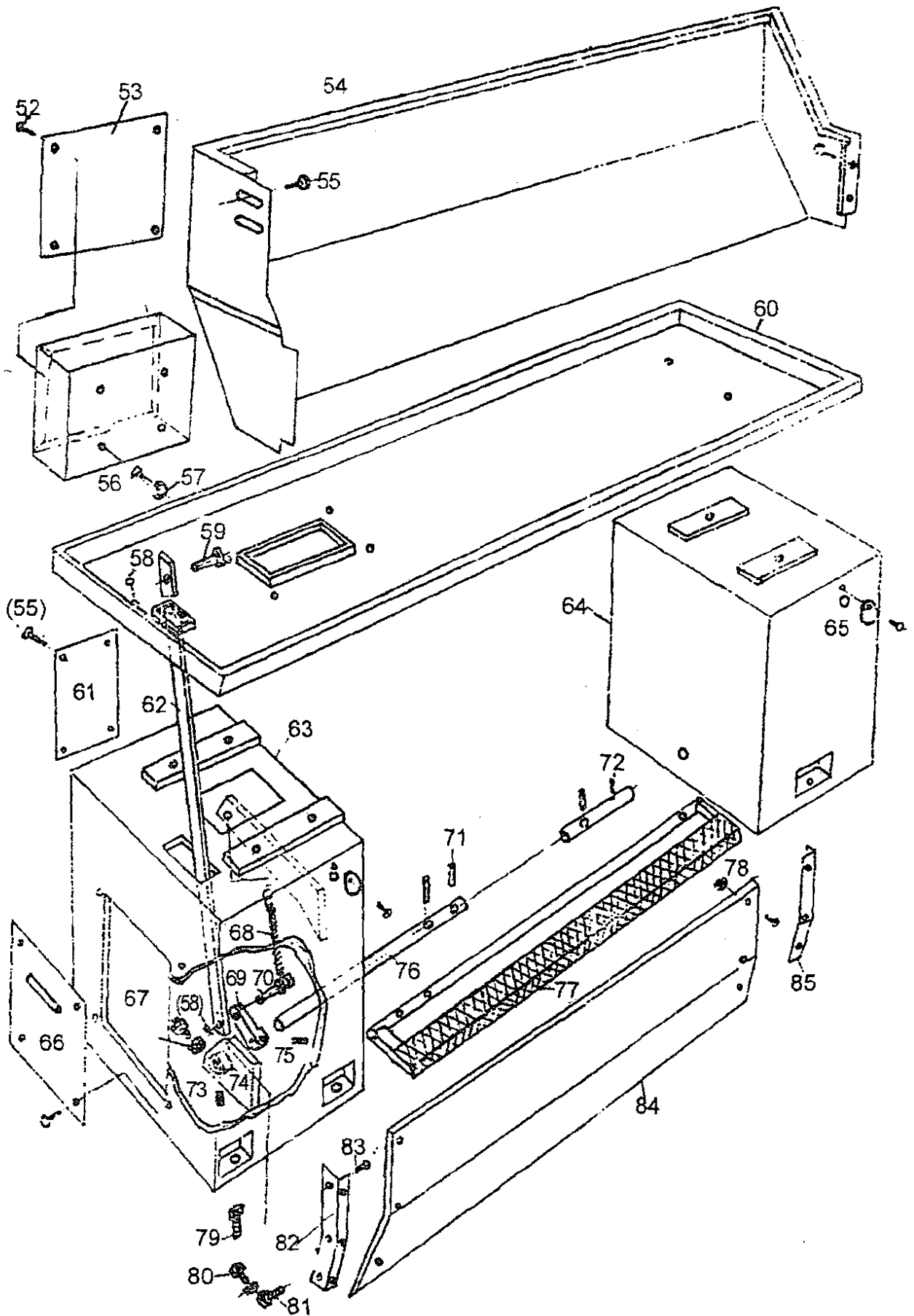

No.	Part No.	Name	Specification
1	01110	Platform	
2	01101	Bed	
3	01102	Bridge	
4	GB77	Screw	
5	GB70	Screw	M10×40
6	GB6172	Nut	M8
7	GB881	Pin	8×66
8	01106	Pulley	
9	GB5783	Bolt	M10×30
10	GB5782	Bolt	M12×60
11	01203	Rack	
12	GB117	Pin	6×28
13	01204	Rack	
14	GB70	Screw	M6×22
15	GB70	Screw	M6×25
16	01205	Feed Shaft	
17	01206	Third-Rod Shaft	
18	01207	Shaft	
19	GB78	Screw	M5×8
20	01208	Criclip	
21	GB879	Pin	3×25
22	CM6233-2017a	Shaft sheath	
23	GB308	Ball	6
24	GB2089	Spring	
25	01212	Collar	
26	GB117	Pin	6×55
27	01502	Plug	
28	GB119-86	Pin	
29	GB70	Screw	M8×8
30	GB2089	Spring	0.8×5×25
31	C0632-01011 5/6	Pin	
32	GB70	Screw	M6×16
33	GB78	Screw	M6×20
34	GB41	Nut	
35	GB70	Screw	M8×55
36	01503	Pug	
37	GB1155	Oil Cup	8
38	01504	Plug	
39	01113	Bracket	
40	C0632-01011	Key	
41	C0632-01011 3/6	Collar	
42	GB2089	Spring	
43	C0632-01011 1/6	Bracket	

No.	Part No.	Name	Specification
44	C0632F-01011 4/6	Bracket	
45	GB879	Pin	
46	C0632F-01011 6/6	Lever	
47	GB4741.14	Cover	
48	04247	Nut	
49	04244	Screw	
50	01209	Shaft	
51	C0632A-04513b	Cover(13 " )	
51	C0636A-04513b	Cover(14 " )	
52	GB818	Screw	M5×6
53	12206a	Cover	
54	01224	Splash Guard	
55	GB823	Screw	M6×10
56	GB818	Screw	M6×20
57	GB97.1	Washer	6
58	GB91	Pin	2×12
59	11212	Pin	
60	01223	Oil Plate	
61	01230	Rear Connecting Plate	
62	11208	Brake Pull Rod	
63	01229	Left Mounting Feet	
64	01228	Right	
65	01234	Round Cover	
66	01231	Right Mounting Feet	
67	11213	Cap-Shape Screw	
68	11204	Draw Spring	
69	11206	Pedal Arm	
70	11205	Pin	
71	GB879	Pin	3×25
72	11201	Shaft	
73	GB78	Screw	M8×6
74	11209	Nut	
75	GB879	Spring Pin	
76	11203	Pedal Shaft	
77	11202	Brake	
78	GB5781	Screw	
79	GB5781	Screw	M12×50
80	GB5781	Screw	M10×60
81	01232	Screw	
82	01235-2/3	Base Plate	
83	GB823	Screw	M6×10
84	01235-1/3	Behind Plate	
85	01235-3/3	Front Plate	

### 12. HEADSTOCK (1/3)

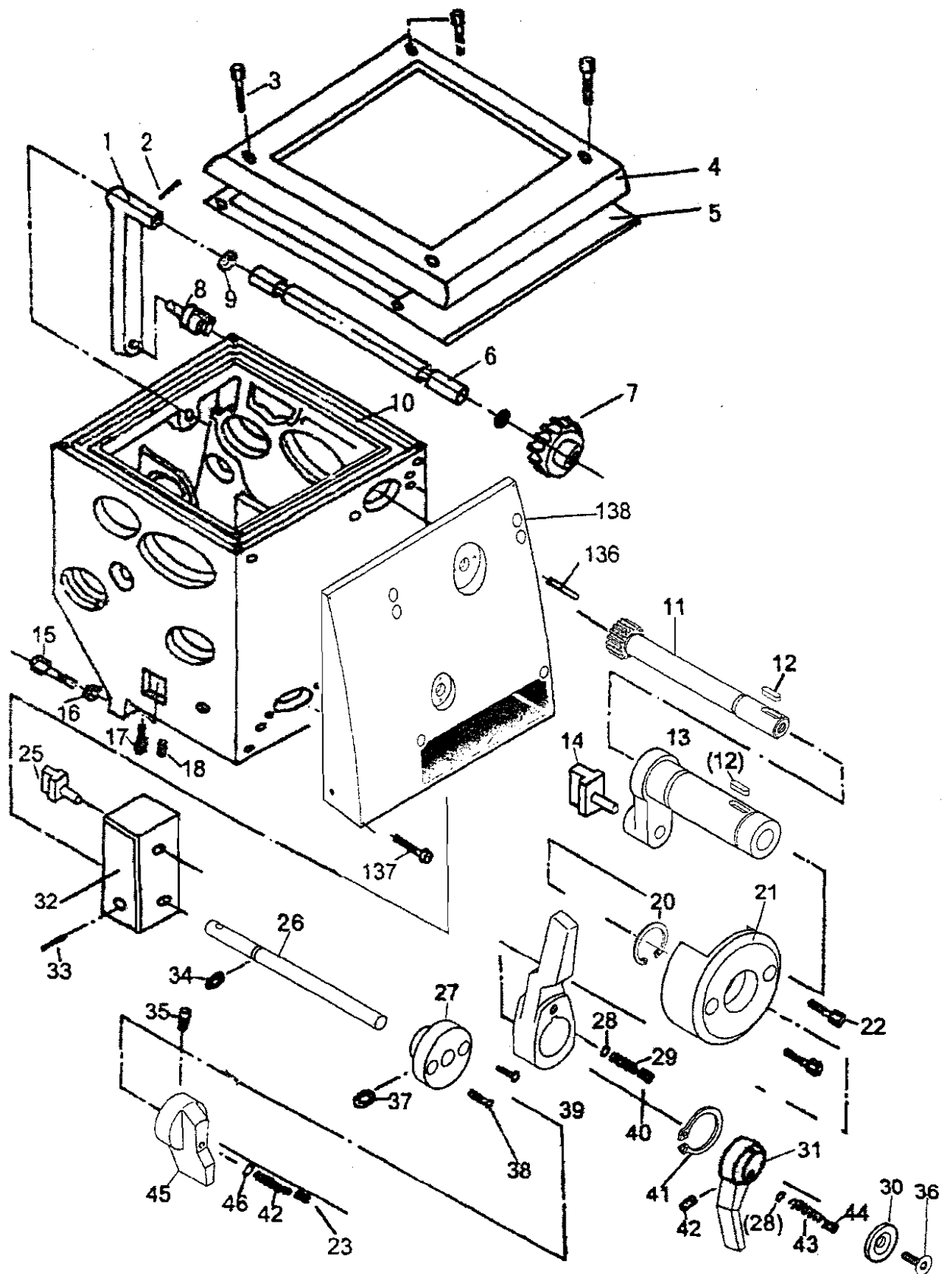

# HEADSTOCK (2/3)

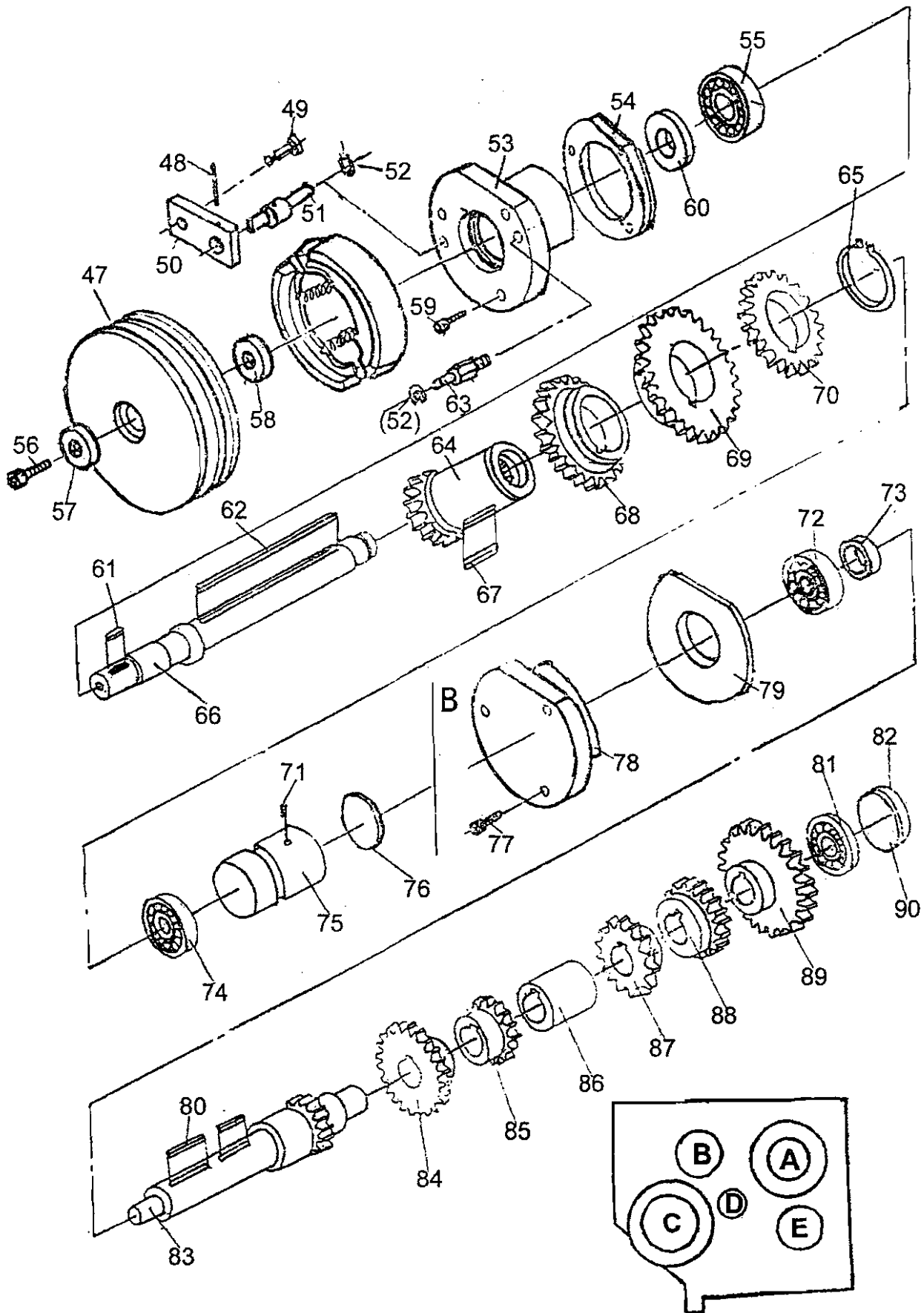

### HEADSTOCK (3/3)

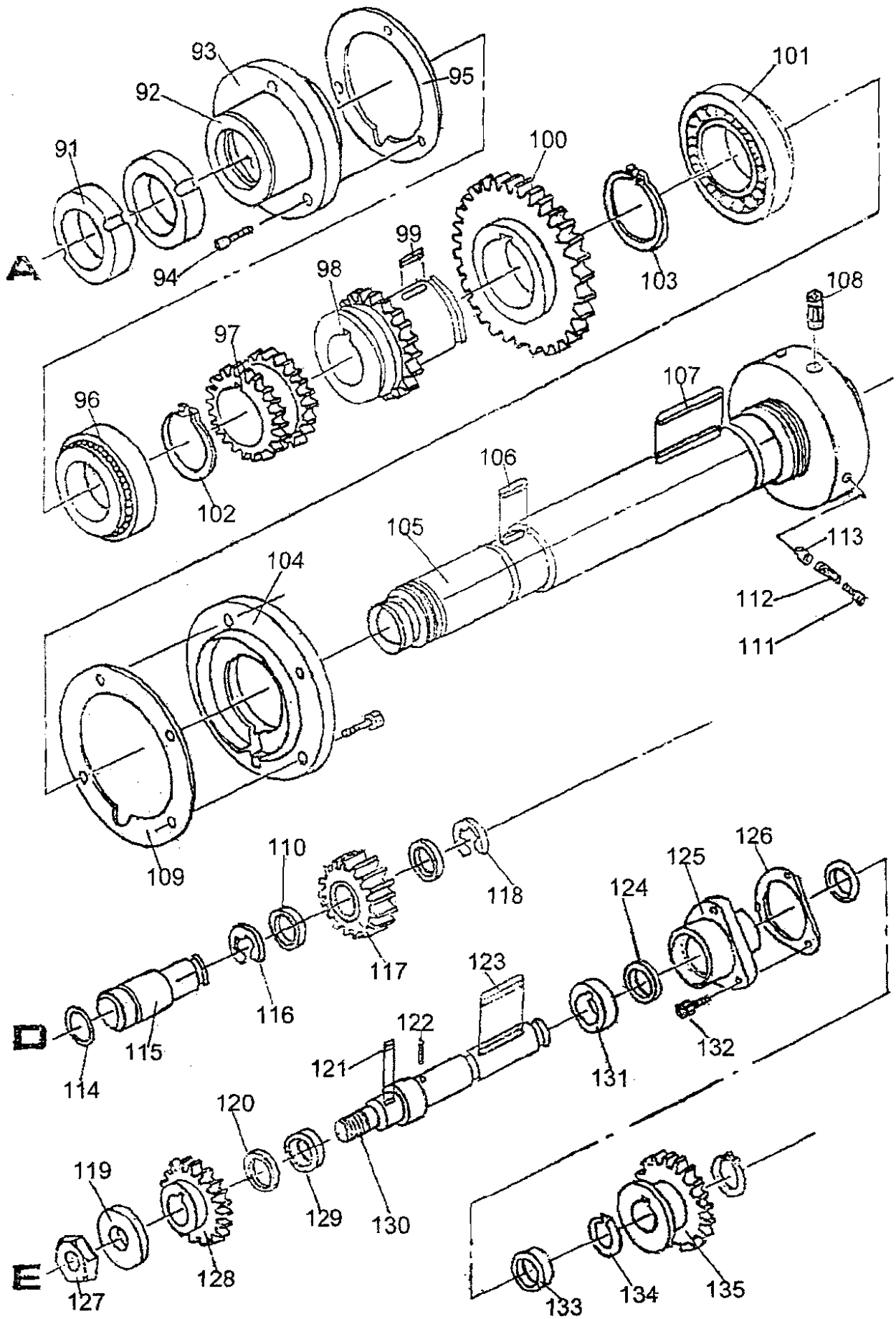

No.	Part No.	Name	Specification
1	32C-04109	Shift Lever	
2	GB879-86	Pin	5×32
3	GB70-85	Screw	M6×18
4	32C-04112b	Casting Cover	
5	32C-04506	Gasket	
6	32-04232	Shaft	
7	32-04234	Gear	
8	32-04233	Shift Lever	
9	GB1235-76	O-Ring	14×2.4
10	32A-04107	Main Casting (13 " )	
10	36A-04107	Main Casting (14 " )	
11	32C/36C-04254b	Gear Shaft (13 " /14 " )	
12	GB1096-79	Key	5×14
13	32A/36A-04216b	Thrift Collar(13 " /14 " )	
14	32-04403	Shift Fork	
15	GB5783-86	Screw	M8×45
16	GB6172-86	Nut	M8
17	GB70-85	Screw	M10×35
18	GB78-85	Screw	M8×12
19	32-04240	Washer	
20	GB1235-76	O-Ring	30×3.1
21	32C-04115b	Cover	
22	GB70-85	Screw	M6×30
23	GB78-85	Screw	M6×16
25	32-04402	Shift Fork	
26	32A-04255b	Shaft	
27	32C-04235b	Collar	
28	GB308-84	Bell Steel	6
29	GB2089-80	Spring	1×6×7
30	32C-04242	Washer	
31	32C-04114	Handle	
32	32-04111	Shift Shaft	
33	GB879-86	Pin	4×18
34	GB1235-76	O-Ring	10×1.9
35	GB78-85	Screw	M6×16
36	32C-04243	Screw	
37	GB1235-76	O-Ring	20×2.4
38	GB70-85	Screw	M4×12
39	32C-04116b	Handle	
40	GB78-85	Screw	M8×8
41	GB894.1-86	Circlip	30
42	GB2089-80	Spring	0.6×4.4×16
43	GB2089-80	Spring	1×6×20
44	GB78-85	Screw	M8×10
45	32C-04110b	Handle	
46	GB308-84	Bell Steel	5

No.	Part No.	Name	Specification
47	32-04122	Pulley	
48	GB879-86	Pin	5×25
49	32-11212	Pin	
50	32-11210	Rocker	
51	32-11209	Rocker Shaft	
52	GB894.1-86	Circlip	8
53	32-04124	Cover	
54	32-04501-1	Gasket	
55	GB276-98	Thrust	105E
56	GB70-85	Screw	M8×15
57	32-04253	Washer	
59	GB70-85	Screw	M6×16
60	HG4-692-67	Oil Seal	SD25×40×10
61	GB1096-79	Key	8×20
62	GB1096-79	Key	6×120
63	32-11211	Shaft	
65	GB894.1-86	Circlip	35
66	32-04252	Shaft	
64	32-04217	Collar	2×2
67	GB1096-79	Key	5×50
68	32-04218	Gear	2×29
69	32-04219	Gear	2×46
70	32-04220	Gear	2×38
71	GB78-85	Screw	M8×16
72	GB276-88	Thrust	204E
73	32-04211	Washer	
74	GB276-88	Thrust	203
75	32-04106	Front Plug	
76	GB1235-76	O-Ring	40×3.1
77	GB70-85	Screw	M4×12
78	32-04123	Behind Cover	
79	32-04502-1	Gasket	
80	GB1096-79	Key	6×55
81	GB276-88	Thrust	204D
82	GB1235-76	O-Ring	47×3.1
83	32-04212	Shaft	2.25×16
84	32-04210	Gear	2×51
85	32-04209	Gear	2×43
86	32-04221	Washer	
87	32-04222	Gear	2×26
88	32-04223	Gear	2×34
89	32-04224	Gear	2.25×53
90	32-04225	Front Plug	
91	32-04208	Nut	
92	32-04102	Collar	
93	32-04103	Behind Cover	

No.	Part No.	Name	Specification
94	GB78-85	Screw	M6×25
95	32-04503	Gasket	
96	GB297-89	Thrust	7210E
97	32-04207	Gear	2×37
98	32-04227	Gear	2.25×37
99	GB1096-79	Key	8×18
100	32-04226	Gear	2.25×74
101	GB297-89	Thrust	7212D
102	GB894.1-86	Circlip	50
103	GB894.1-86	Circlip	72
104	32-04108	Front Cover	
105	32-04228	Spindle	
106	GB1096-79	Key	6×40
107	GB1096-79	Key	8×85
108	32-04231	Cam	
109	32-04505	Gasket	
110	GB276-88	Thrust	7000104E
111	GB70-86	Screw	M8×18
112	32-04229	Spindle	
113	32-04230	Pin	
114	GB1235-76	O-Ring	25×2.4
115	32-04238	Shaft	
116	GB893.1-86	Circlip	42
117	32-04237	Gear	
118	GB893.1-86	Circlip	42
119	32-04206	Washer	
120	32-04204	Washer	
121	GB1096-79	Key	5×18
122	GB879-86	Pin	3×10
123	GB1096-79	Key	6×50
124	32-04401	Collar	
125	32-04101	Collar	
126	32-04504	Gasket	
127	GB6172-86	Nut	M12
128	32-04205	Gear	
129	32-04507	Oil Seal	
130	32-04239	Shaft	
131	32-04203	Washer	
132	GB70-85	Screw	M5×16
133	32-04202	Washer	
134	GB894.1	Circlip	20
135	32-04201	Gear	
136	GB117-86	Taper Pin	6×35
137	GB70-85	Screw	M6×30
138	32A/36A-04125b	Frame (13 " /14 " )	

### 13.GEARBOX (1/3)

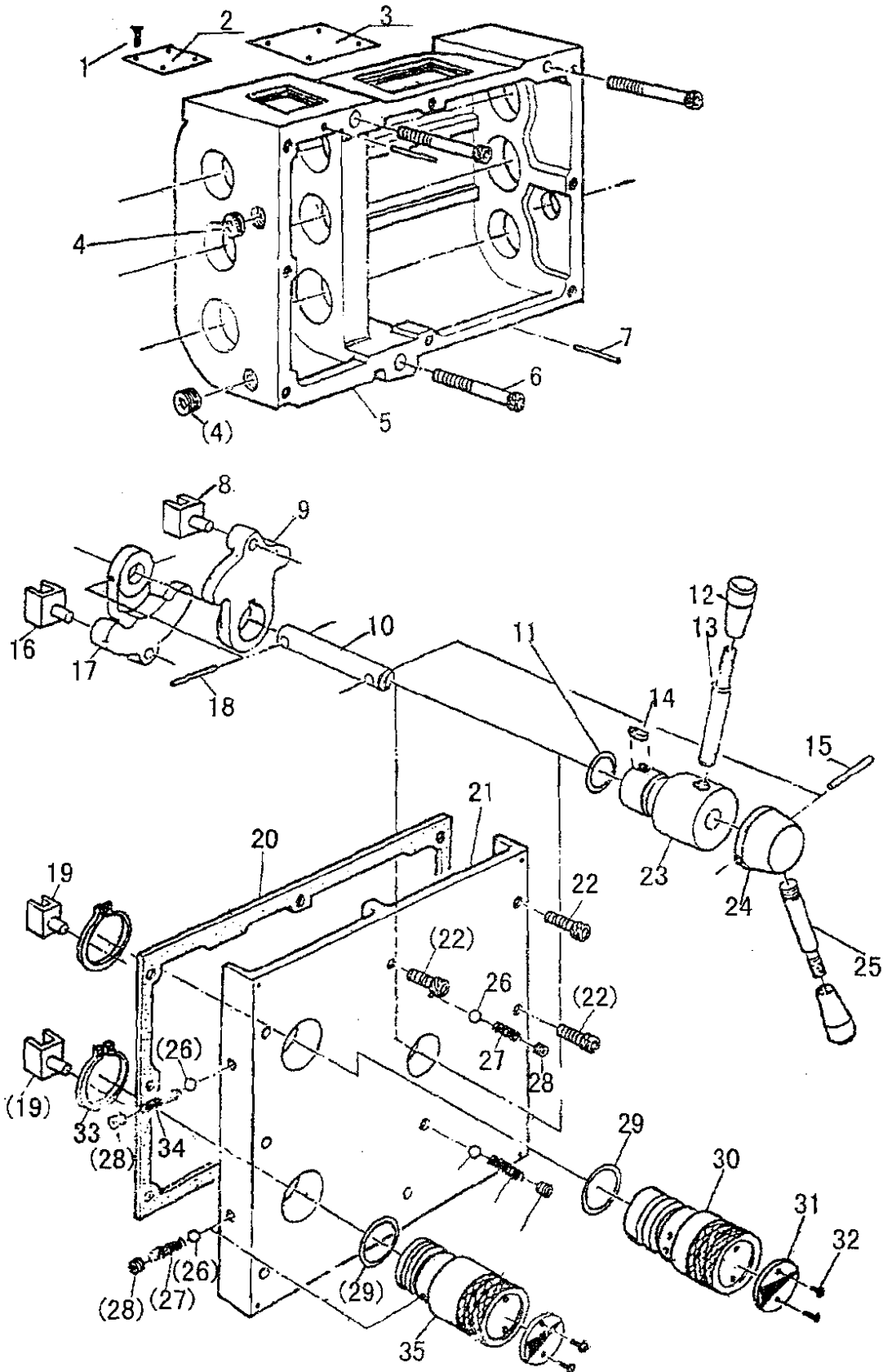

### GEARBOX (2/3)

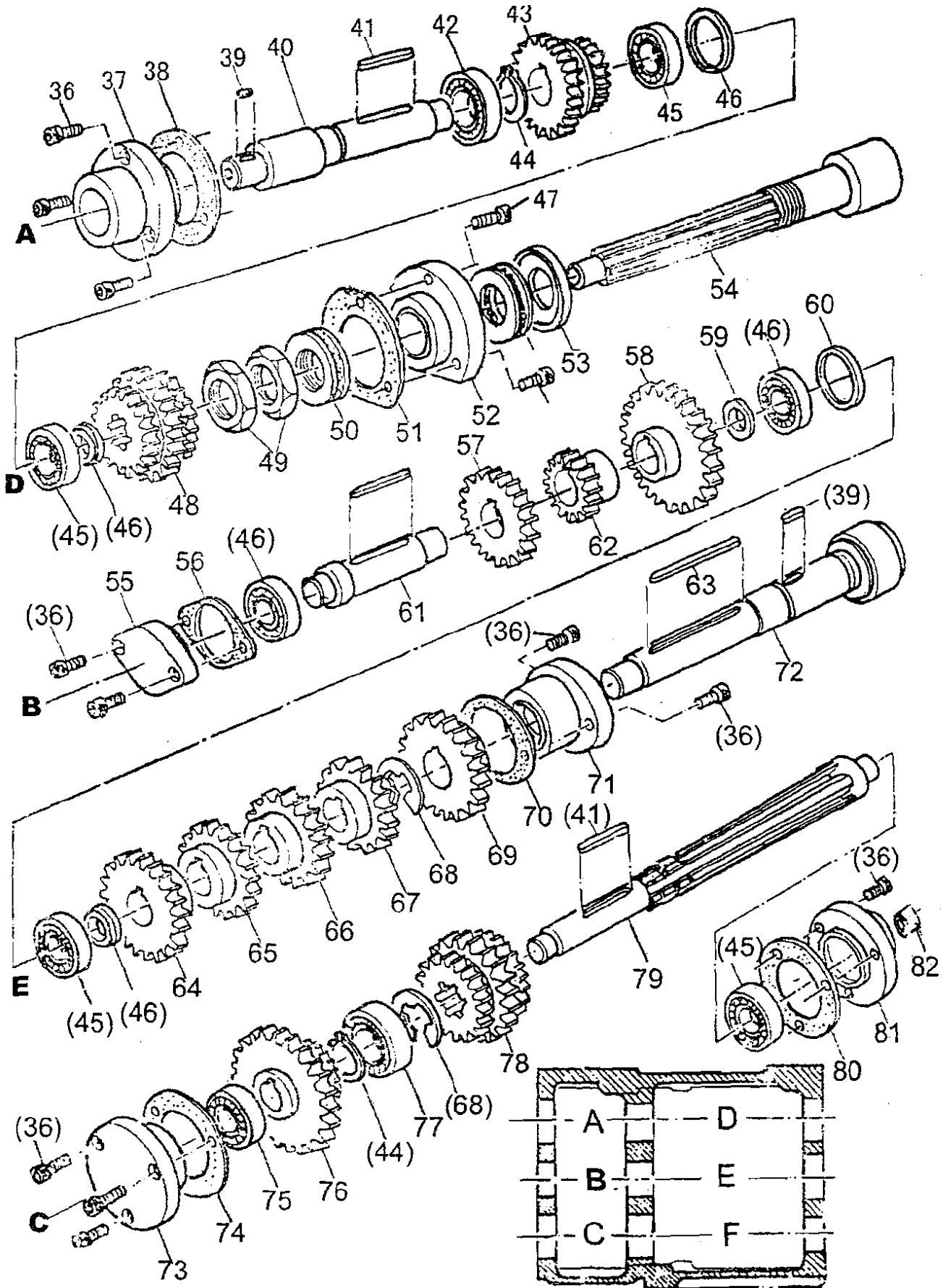

# GEARBOX (3/3)

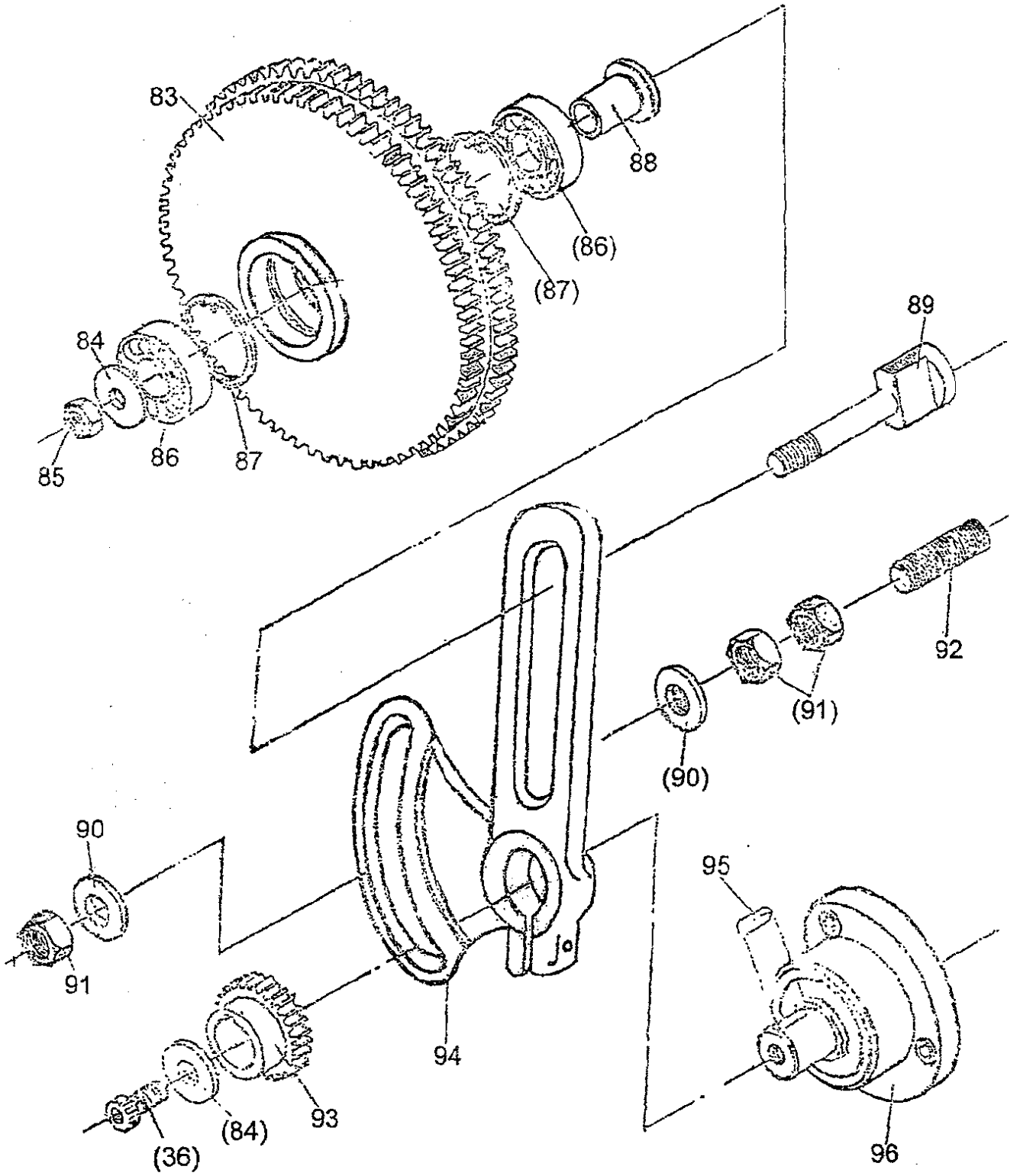

No.	Part No.	Name	Specification
1	GB819	Screw	M4×8
2	05-51	Left Cover	
3	05-52	Right Cover	
4	Q/ZB285.3	Nut	ZG3/8"
5	05-11	Casting	
6	GB70	Screw	M8×65
7	GB879	Pin	5×40
8	05-08	Slipper	
9	05-10	Lever	
10	05-04	Shaft	
11	GB3452.1	O-Ring	25×265
12	GB4141.14	Cover	BM10×50
13	05-01	Lever & Ball	
14	GB1096	Key	5×8
15	GB879	Pin	5×50
16	05-53	Slipper	
17	05-09	Lever	
18	GB879	Pin	5×20
19	05-30	Slipper	
20	05-07	Gasket	
21	C0632A-05113b	Cover	
22	GB70	Screw	M6×20
23	05-03	Handle Base	
24	05-02	Handle Base	
25	05-01	Lever & Ball	
26	GB308	Bell Steel	Φ6.5
27	GB2089	Spring	0.8×5×15
28	GB77	Screw	M8×6
29	GB3452.1	O-Ring	34.5×2.65
30	05-31	Handle	
31	04-49	Washer	
32	GB818	Screw	M3×8
33	GB894.1	Circlip	40

No.	Part No.	Name	Specification
34	GB2089	Spring	
35	05-32	Handle	
36	GB70	Screw	M6×14
37	05-29	Cover	
38	05-25	Gasket	
39	GB1096	Key	5×14
40	05-39	Shaft	
41	GB1096	Key	5×50
42	GB276	Thrust	104
43	05-38	Gear	
44	GB894.1	Circlip	20
45	GB276	Thrust	202
46	05-44	Washer	
47	GB70	Screw	M6×20
48	05-50	Gear	
49	05-46	Nut	
50	GB301	Thrust	8105
51	05-47	Gasket	
52	05-48	Bush	
53	05-49	Washer	
54	05271	Shaft	
55	05-28	End Cover	
56	05-27	Gasket	
57	05-36	Gear	
58	05-40	Gear	
59	05-42	Washer	
60	05-43	Washer	
61	05-41	Shaft	
62	05-37	Gear	
63	GB1096	Key	
64	05-22	Gear	
65	05-21	Gear	
66	05-10	Gear	

No.	Part No.	Name	Specification
67	05-18	Gear	
68	GB894.1	Circlip	22
69	05-17	Gear	
70	05-16	Gasket	
71	05-14	Flange	
72	05270	Shaft	
73	05-26	End Cover	
74	05-25	Gasket	
75	GB276	Thrust	302
76	05-24	Gear	
77	GB276	Thrust	104
78	05-20	Gear	
79	05-23	Key Shaft	
80	05-15	Cover	
81	05-13	Cover	
82	05111	Bush	
83	05269	Gear	
84	05-33	Washer	
85	GB6175	Nut	M10
86	GB276	Thrust	103
87	GB893.1	Circlip	35
88	05266	Collar	
89	05268	Screw	
90	05267	Washer	
91	GB6172	Nut	M10
92	05249	Screw Rod	
93	05258	Gear	
94	C0632A-05112b	Gear Frame	
95	GB1096	Key	5×14
96	05-29	Cover	

### 14. APRON (1/3)

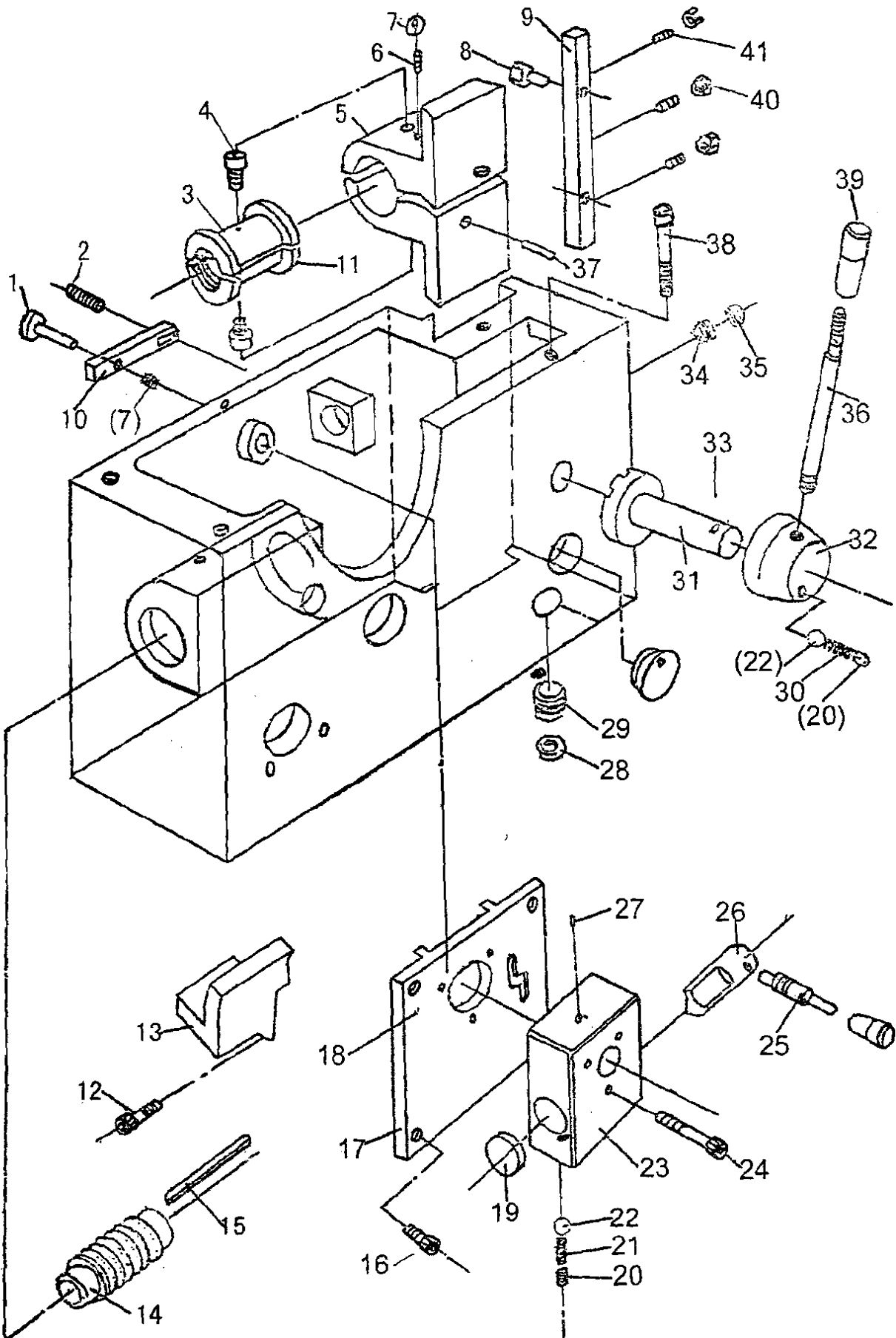

### APRON (2/3)

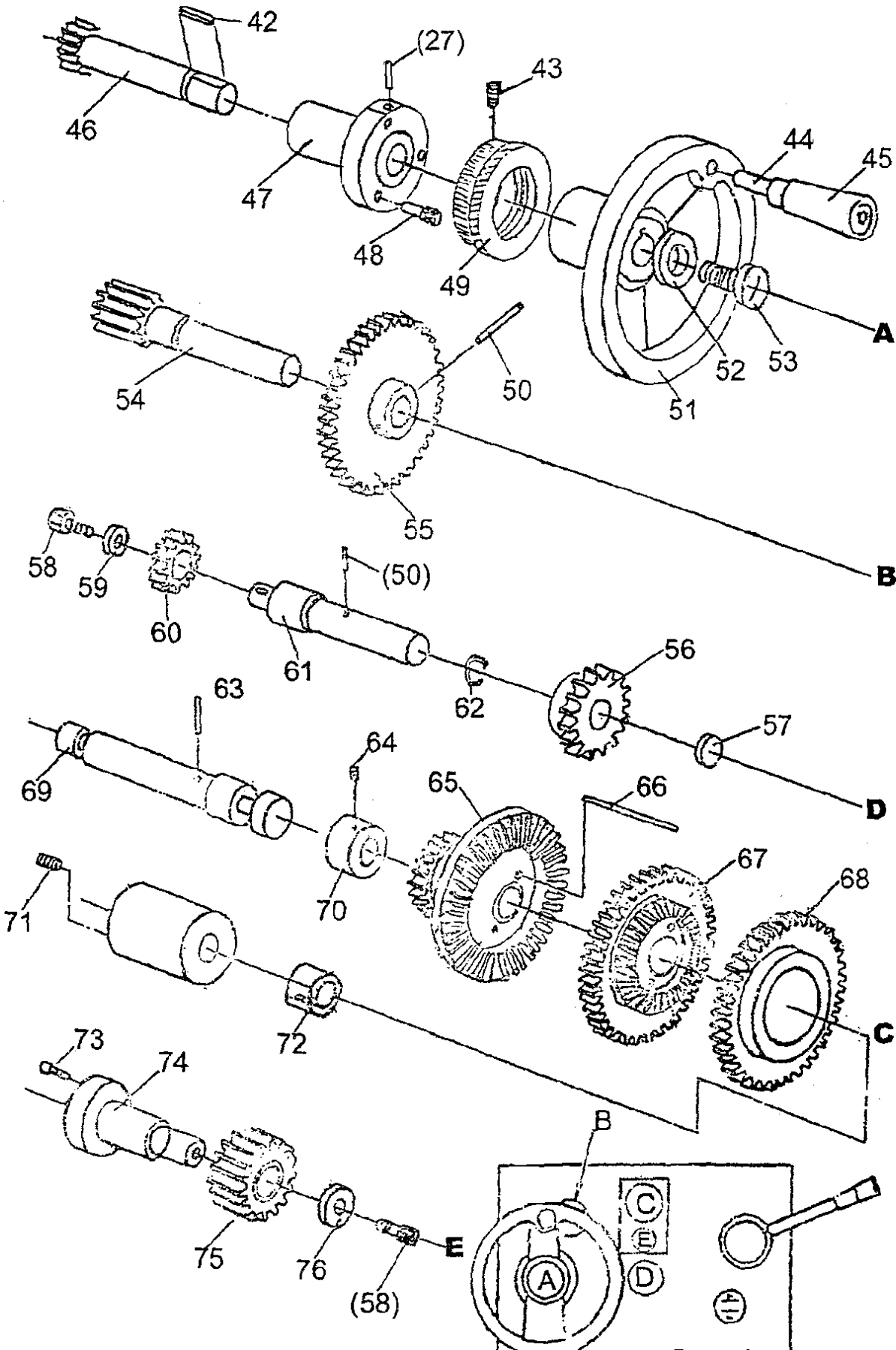

APRON (3/3)

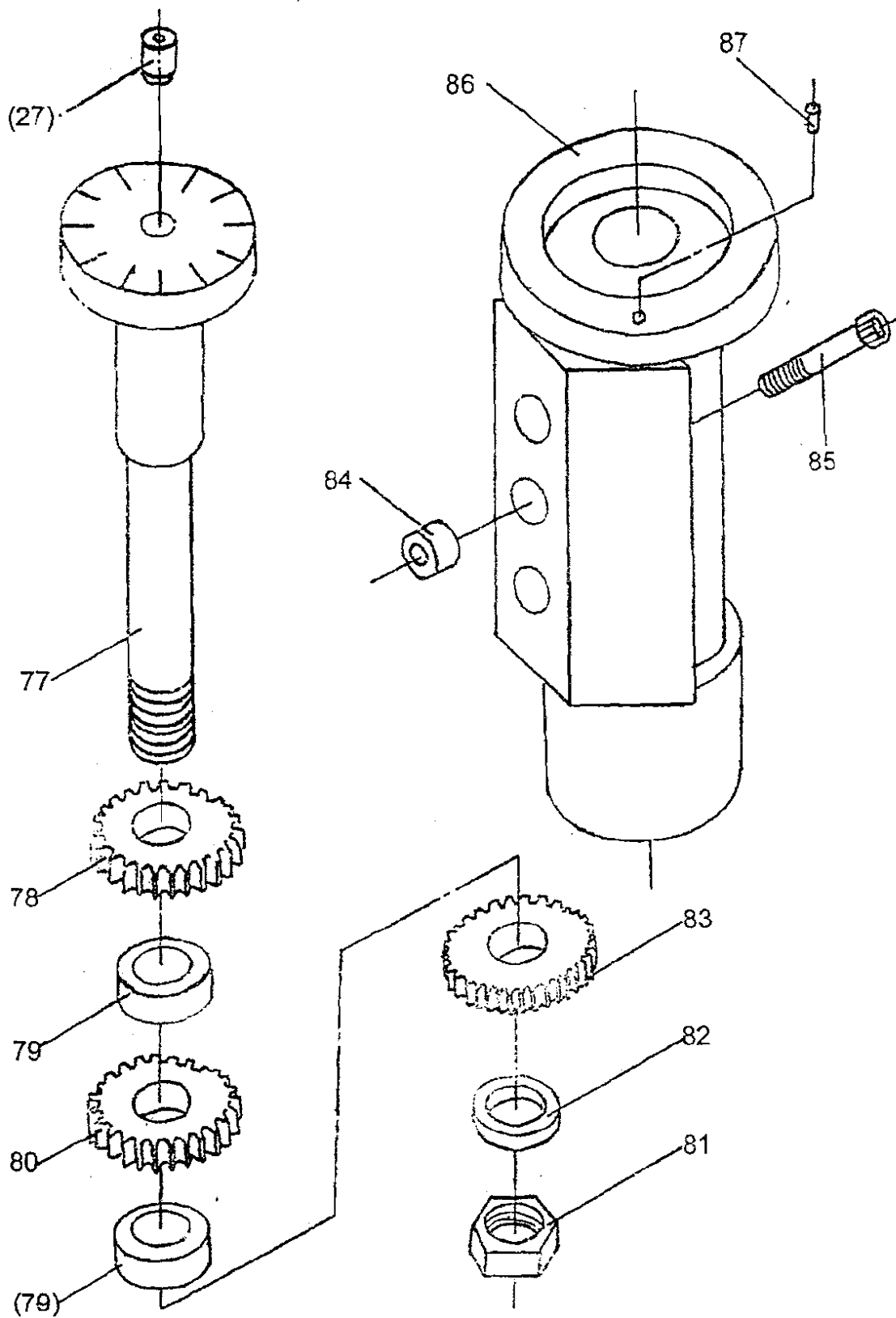

No.	Part No.	Name	Specification
1	06213	Gear	
2	GB77	Screw	M6×10
3	06427	Haft Nut	
4	GB5783	Screw	M6×12
5	06126	Nut	
6	GB77	Screw	M6×35
7	GB6170	Nut	M6
8	GB5783	Screw	M5×16
9	06107	Gib	
10	06238	Shank	
11	02335	Shaft	
12	GB70	Screw	M6×16
13	06415	Shield	
14	06228	Worm	
15	06260	Key	
16	GB70	Screw	M6×12
17	06104	Cover	
18	GB879	Pin	5×20
19	06554	Plug A	
20	GB78	Screw	M6×6
21	06258	Spring	
22	GB308	Bell Steel	5
23	06103	Foundation	
24	GB70	Screw	M6×35
25	06223	Shift Lever	
26	06222	Shift Lever	
27	GB1155	Oil	8
28	G52.5	Washer	10
29	GB8-2	Plug	M10×1
30	06257	Spring	
31	06225	Shaft	
32	06208	Handle	
33	GB879	Pin	5×32
34	06548	Oil Sight Collar	
35	06549	Oil Sight Collar	
36	06209	Handle	
37	GB119	Pin	8N6×12
38	GB70	Screw	M8×30
39	06553	Lever	
40	GB6170	Nut	M5
41	GB77	Screw	M5×16
42	GB1096	Key	A5×18
43	GB78	Screw	M5×5
44	06239	Screw	

No.	Part No.	Name	Specification
45	06556	Lever	
46	06212	W-Shaft	
47	06105	Guard	
48	GB70	Screw	M6×25
49	06510	Index Ring	
50	GB879	Pin	5×30
51	06102	Handwheel	
52	06241	Washer	
53	GB823	Screw	M6×12
54	06214	V-Shaft	
55	06213	Gear	
56	06224	Gear	
57	06555	Plug B	
58	GB5783	Screw	M6×10
59	06242	Washer	
60	06429	Worm Gear	
61	06230	IV-Shaft	
62	GB125	O-Ring	2.4×20
63	GB897	Pin	3×25
64	GB78	Screw	M6×10
65	06218	Gear	
66	GB119	Pin	5NN×25
67	06219	Gear	
68	06220	Gear	
69	06216	III-Shaft	
70	06417	Cover	
71	GB77	Screw	M6×6
72	06421	Shift Fork	
73	GB70	Screw	M5×12
74	06232	II -Shaft	
75	06231	Worm Gear	
76	06240	Washer	
77	06233	Shaft	
78	06436	Gear	
79	06237	Washer	
80	06435	Gear	
81	GB6170	Nut	M8
82	GB859	Washer	8×1.6×2.5
83	06434	Gear	
84	06206	Washer	
85	GB70	Screw	M8×50
86	06105	Guard	
87	GB827	Rivet	3×8

### 15. CROSS SLIDE (1/2)

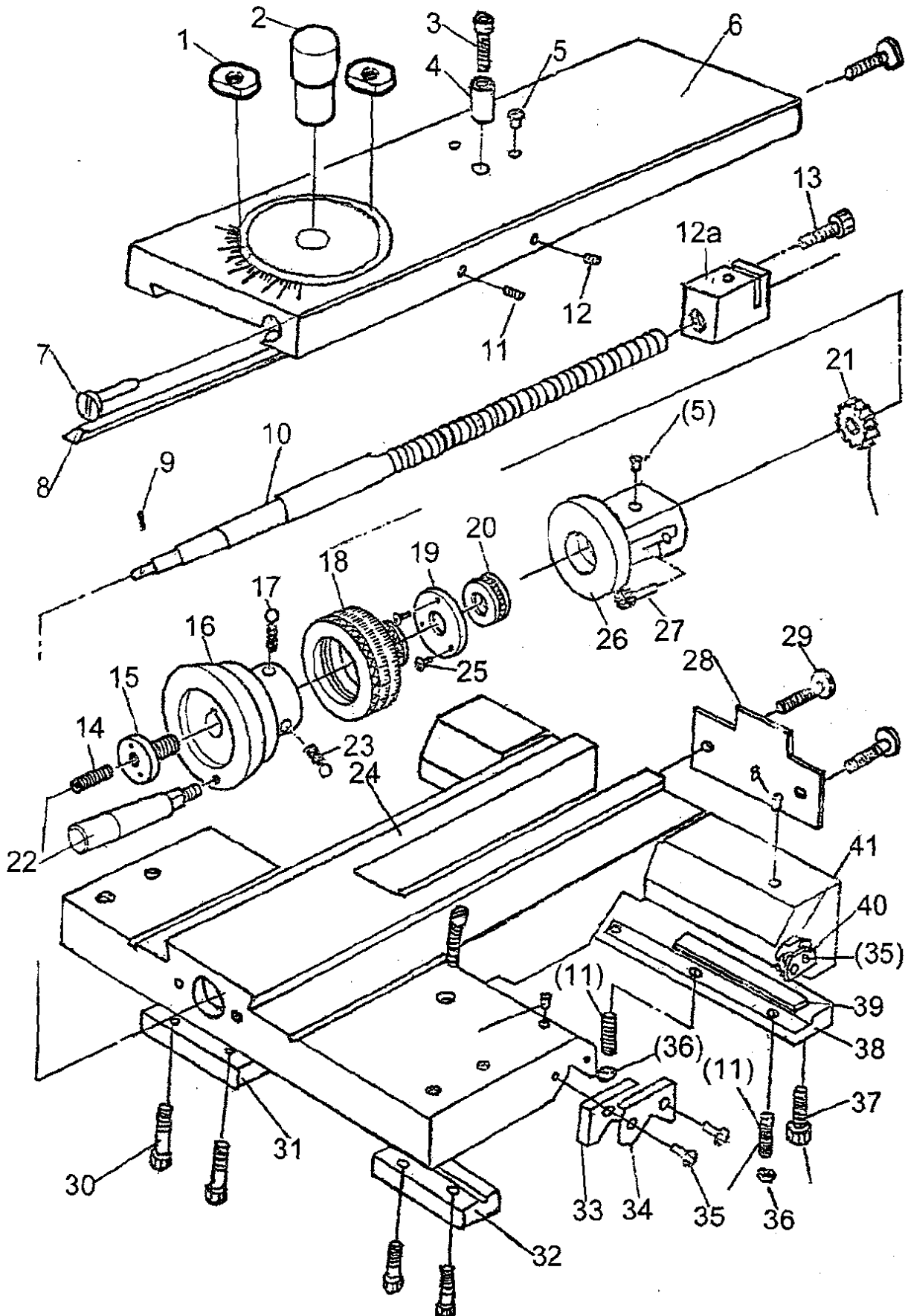

### CROSS SLIDE (2/2)

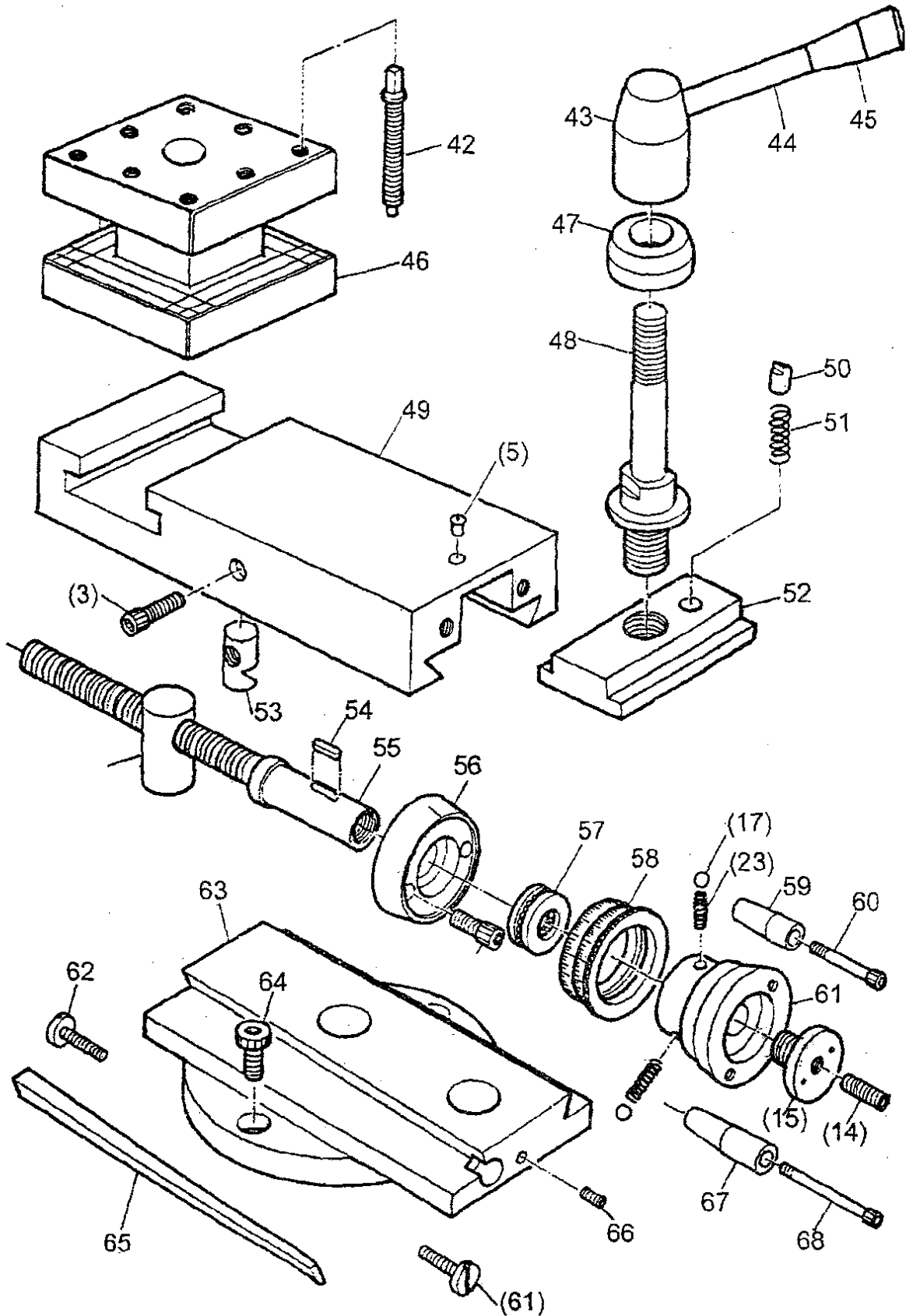

No.	Part No.	Name	Specification
1	CL6132-07-07	Slide	
2	CL6132-07-08	Slide Axis	
3	GB70	Screw	M6×16
4	C0632-07216	Bushing	
5	GB1155	Oil Cup	
6	CT0632-07-01	Cross Slide	
7	CM6233-3023	Bolt	
8	CM6033-3022	Gib	
9	GB879	Pin	3×16
10	CT0632-07-05	Leadscrew	
11	GB77	Screw	6×26
12	GB77	Screw	M8×10
12a	C0632-07415	Nut	
13	GB78	Screw	M6×16
14	GB78-85	Screw	M6×25
15	CL6132-07-15	Screw	
16	CL6132-07-16	Handwheel	
17	GB308	Bell Steel	Φ6
18	CL6132-07-17	Index Ring	
19	CL6132-07-18	Cover	
20	GB301	Bearing	8102
21	CM6233-3013	Gear	
22	C0632-07207b	Lever	
23	GB2089	Spring	0.7×5×9
24	C0632-07101	Saddle Casting	
25	GB818-85	Screw	M5×10
26	C0632-07120	Keep Assr	
27	GB70	Screw	M6×25
28	C0632-07225	Plate	
29	GB823	Screw	M8×12
30	GB5783	Screw	M8×20
31	C0632-07123	Strip	
32	C0632-07141	Front Strip	
33	C0632-07528	Wiper	
34	C0632-07227	Plate	

No.	Part No.	Name	Specification
35	GB823	Screw	M4×12
36	GB6170	Nut	M6
37	GB5783	Screw	M8×25
38	C0632-07132	Strip	
39	C0632-07239	Strip	
40	C0632-07224	Plate	
41	C0632-07526	Wiper	
42	GB83	Screw	M10×50
43	GB4141.16	Collar	BM16×32
44	CL6132-07-36	Bolt	
45	GB4141.14	Collar	M10×50
46	CL6132-07-32	Tool Post	
47	CL6132-07-33	Washer	
48	CL6132-07-34	Shaft	
49	CL6132-07-49	Gib	
50	CL6132-07-29	Wiper	
51	GB2089	Spring	1×8×11
52	CL6132-07-37	Plate	
53	CL6132-07-09	Wiper	
54	GB1096	Key	4×14
55	CL6132-07-40	Leadscrew	
56	CL6132-07-41	Bracket	
57	GB301	Bearing	8103
58	CL6132-07-42	Index Ring	
59	CL6132-07-43	Collar	
60	GB70	Screw	M5×25
61	CL6132-07-48	Handwheel	
62	CL6137-07-28	Screw	
63	CL6132-07-11	Swivel Slide	
64	GB70	Gib	M8×16
65	CL6132-07-10	Screw	
66	GB80	Collar	M6×16
67	CL6132-07-44	Screw	
68	GB70	Screw	M5×40

### 16. TAILSTOCK (1/2)

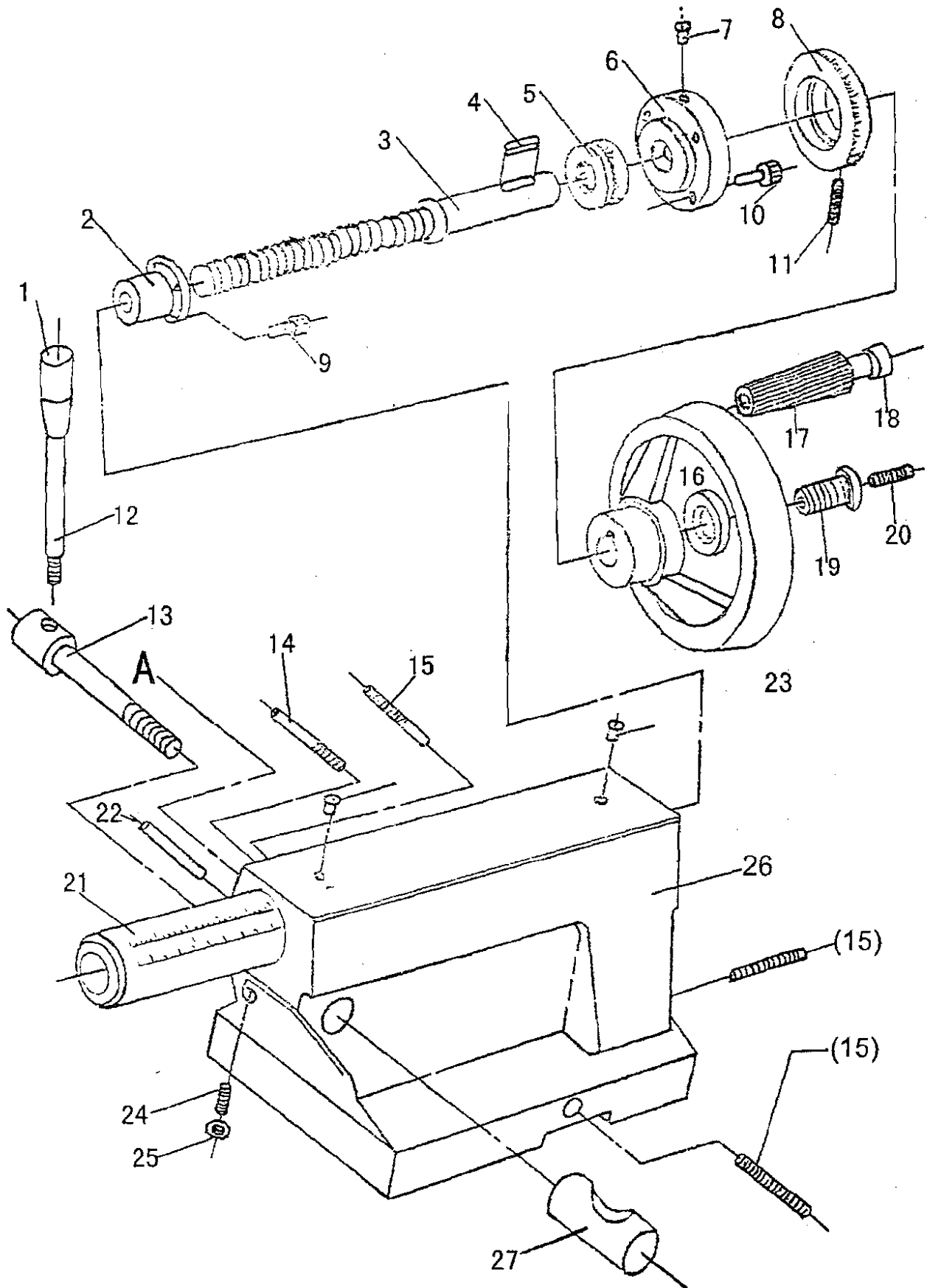

### TAILSTOCK (2/2)

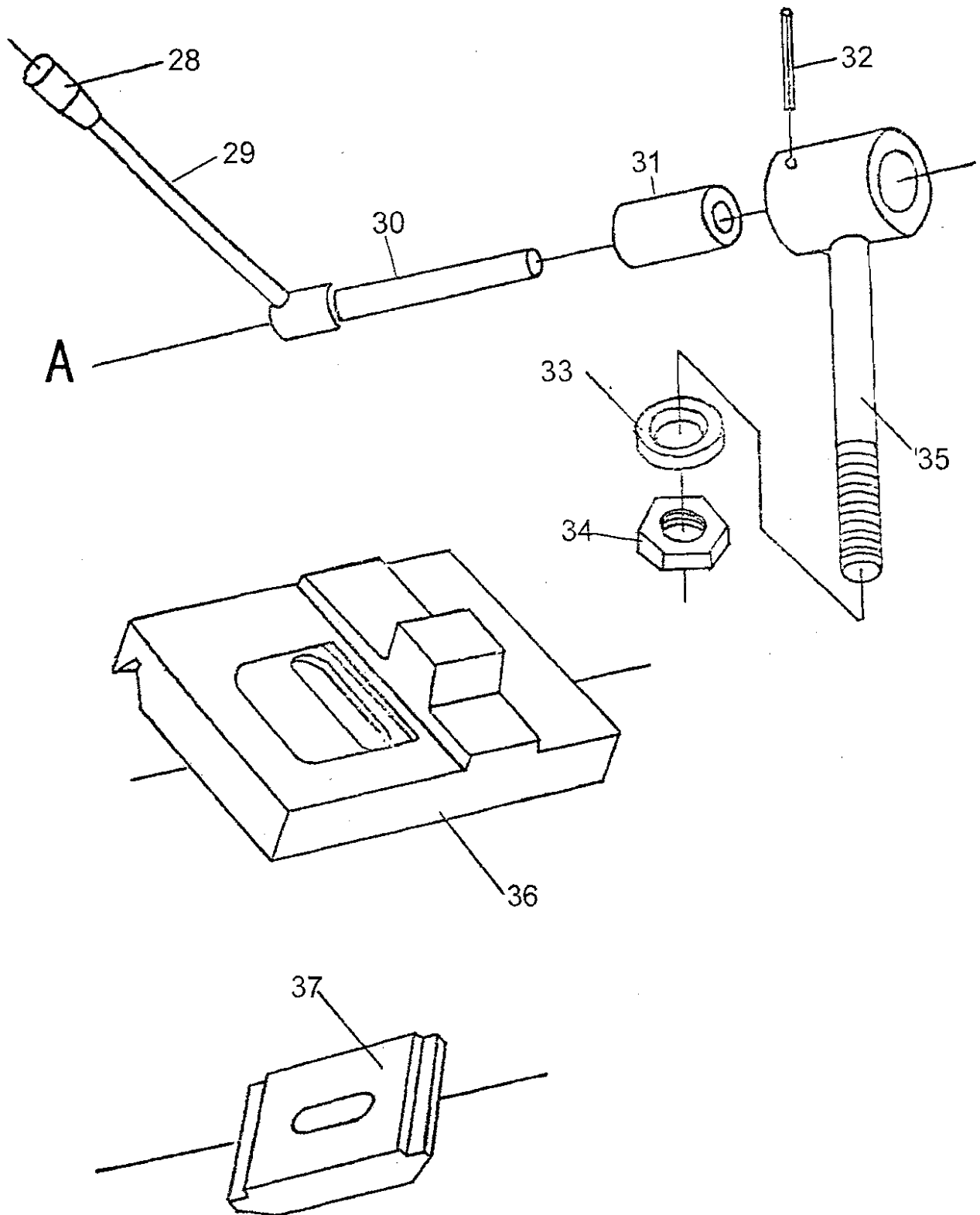

No.	Part No.	Name	Specification
1	JB1342	Gover	M8×40
2	08401	Nut	
3	08203	Screw	
4	GB1096	Key	4×15
5	GB301	Thrust	8102
6	08102	Hanger Cover	
7	GB1155	Oil	8
8	08402	Index Ring	
9	GB70	Screw	M4×10
10	GB70	Screw	M6×16
11	GB78	Screw	M6×10
12	08207	Screw	
13	08208	Shaft	
14	08209	Screw	
15	GB78	Screw	M10×45
16	08204	Washer	
17	08501	Lever	
18	08206	Screw	
19	08205	Screw	
20	GB73	Screw	M5×18
21	08202	Barrel	
22	08209	Screw	
23	08103	Handwheel	
24	GB79	Screw	M8×35
25	GB6172	Nut	M8
26	08101	Casting	
27	08403	Lock Block	
28	JB1342	Gover	M10×50
29	08214	Screw	
30	08213	Shaft	
31	08211	Collar	
32	GB879	Pin	5×24
33	GB97.1	Washer	B12
34	GB6170	Nut	M12
35	08212	Screw	
36	08105	Base	
37	08104	Clamp Plate	

### 17. CENTER REST

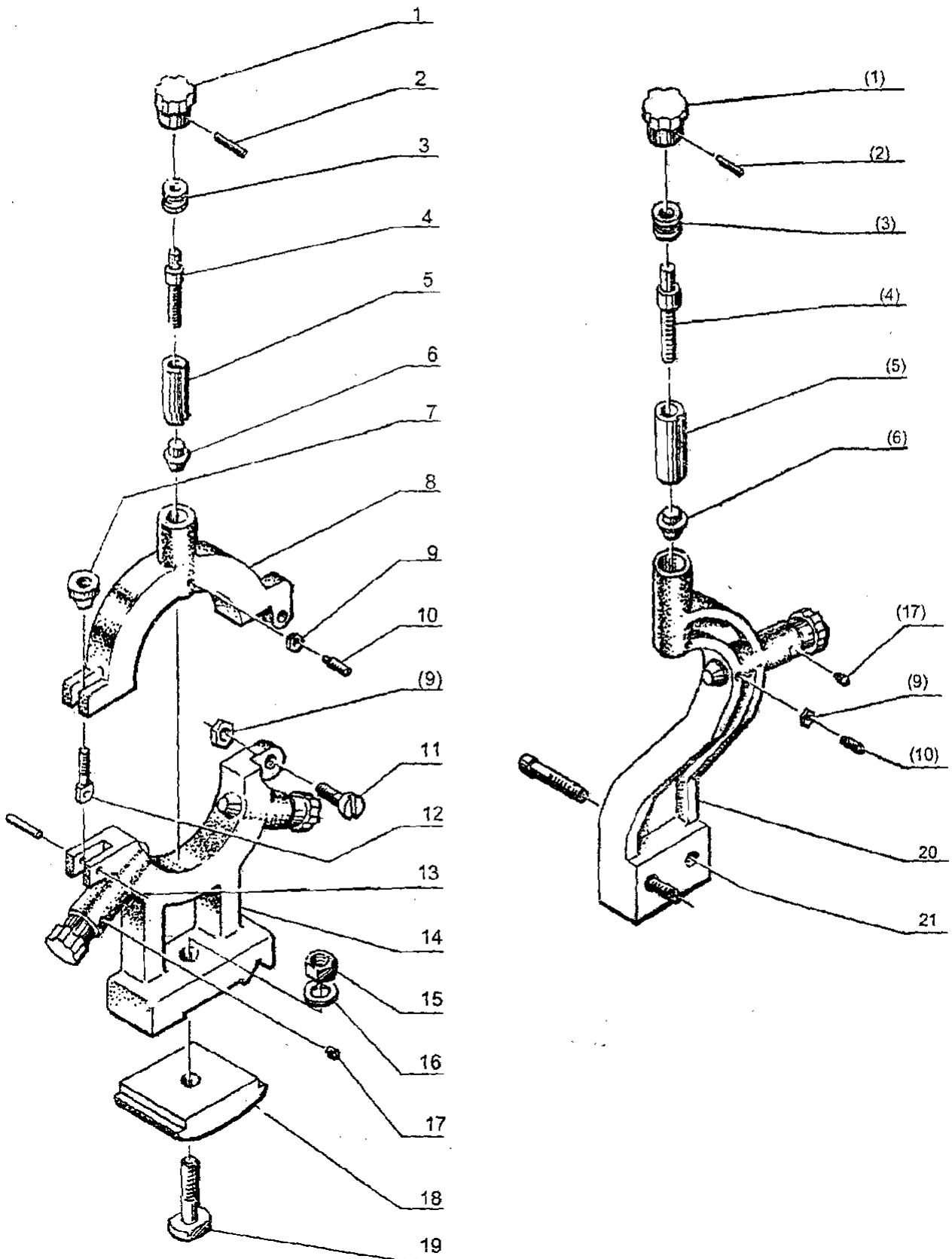

---

No.	Part No.	Name	Specification
1	JB1360	Knob	32×8
2	GB119	Pin	3×18
3	10203	Collar	
4	10204	Screw	
5	10201	Collar	
6	10401	Clapping Head	
7	10205	Nut	
8	10101	Upside Of Center Rest	
9	GB6170	Nut	M6
10	GB79	Screw	M6×18
11	GB65	Screw	M6×30
12	10206	Screw	
13	GB879	Pin	5×24
14	10102	Downside Of Center Rest	
15	GB6170	Nut	M12
16	GB97.1	Washer	12
17	GB78	Screw	M6×6
18	10103	Clamp	
19	GB37	Screw	M12×65
20	10104	Follow Rest	
21	GB70	Nut	M8×46