



**MACHINERY DIVISION**

6465 18 MILE ROAD  
STERLING HEIGHTS, MI 48314

**PHONE:**  
(586) 731-3600 • 1-800-860-1740

**FAX:**  
(586) 731-7464 • 1-800-862-1740

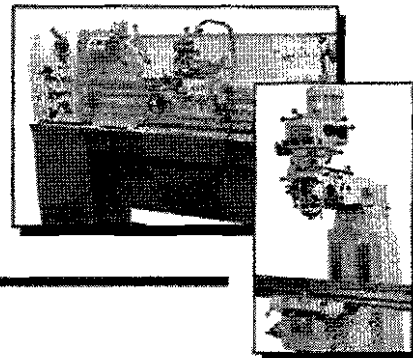

## **MODEL 9648 SANDER**

**THANK YOU FOR PURCHASING WITH KBC MACHINERY. ALL KBC MACHINES ARE BACKED BY OUR 1 YEAR PARTS REPLACEMENT WARRANTY. WHEN USED AS INTENDED, AND WITH PROPER MAINTENANCE THIS MACHINE WILL PROVIDE YOU WITH YEARS OF TROUBLE-FREE SERVICE. IF YOU NEED PARTS SIMPLY FILL OUT THE PARTS REQUEST FORM, AND FAX OR E-MAIL YOUR REQUEST. ALL OTHER QUESTIONS PLEASE CONTACT US @ :**

**KBC MACHINERY  
6465 18 MILE ROAD  
STERLING HEIGHTS, MI 48314  
PH (800) 860-1740  
FAX (800) 862-1740  
[MACHINERY@KBCTOOLS.COM](mailto:MACHINERY@KBCTOOLS.COM)  
[WWW.KBCTOOLSANDMACHINERY.COM](http://WWW.KBCTOOLSANDMACHINERY.COM)**



# PARTS REQUEST FORM

YOUR COMPANY NAME:

STATE/PROVINCE

YOUR NAME

PHONE # + EXT

FAX #

MACHINE INFO:

MAKE/MANUFACTURER

MODEL NUMBER

YEAR MADE

SERIAL#

PARTS REQUESTED:

PART#

DESCRIPTION

PLEASE INCLUDE COPY(S) OF THE PARTS DRAWING FROM THE  
MANUAL AND CIRCLE THE PARTS NEEDED

FAX PARTS REQUEST TO (800) 862-1740

E-MAIL PARTS REQUEST TO: [machinery@kbctools.com](mailto:machinery@kbctools.com)

THANKS; KBC MACHINERY - MICHIGAN

# 6" Belt And 9" Disc Sander

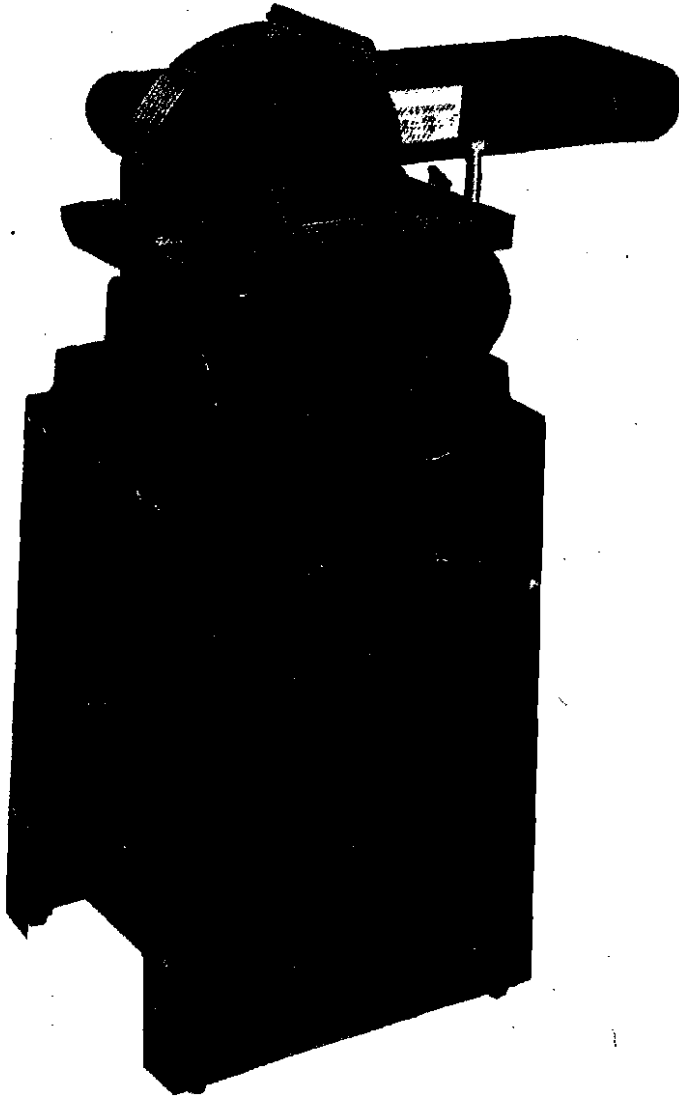

INSTRUCTION MANUAL

Before Using Be Sure To Read This Manual

9648

## Safety Rules

---

1. **KEEP GUARDS IN PLACE** and in working order.
2. **REMOVE ADJUSTING KEYS AND WRENCHES.** Form habit of checking to see that keys and adjusting wrenches are removed from tool before turning it on.
3. **KEEP WORK AREA CLEAN.** Cluttered areas and benches invite accidents.
4. **DON'T USE IN DANGEROUS ENVIRONMENT.** Don't use power tools in damp or wet location, or expose them to rain. Keep work area well lighted.
5. **KEEP CHILDREN AWAY.** All visitors should be kept a safe distance away from work area.
6. **MAKE WORKSHOP KID PROOF** with padlocks, master switches, or by removing starter keys.
7. **DON'T FORCE THE TOOL.** It will do the job better and safer at the rate for which it was designed.
8. **USE RIGHT TOOL.** Don't force the tool or attachment to do a job for which it was not designed.
9. **WEAR PROPER APPAREL.** No loose clothing, gloves, neckties, rings, bracelets, or other jewelry to get caught in moving parts. Nonslip footwear is recommended. Wear protective hair covering to contain long hair.
10. **ALWAYS USE SAFETY GLASSES.** Also use a face or dust mask if cutting operation is dusty. Everyday eyeglasses only have impact resistant lenses, they are NOT safety glasses.
11. **SECURE WORK.** Use clamps or a vise to hold work when practical. It's safer than using your hand and it frees both hands to operate tool.
12. **DON'T OVERREACH.** Keep proper footing and balance at all times.
13. **MAINTAIN TOOLS WITH CARE.** Keep tools sharp and clean for best and safest performance. Follow instructions for lubricating and changing accessories.
14. **DISCONNECT TOOLS** before servicing; when changing accessories such as blades.
15. **REDUCE THE RISK OF UNINTENTIONAL STARTING.** Make sure switch is in off position before plugging in.
16. **USE RECOMMENDED ACCESSORIES.** Consult the owner's manual for recommended accessories. The use of improper accessories may cause risk of injury to persons.
17. **NEVER STAND ON TOOL.** Serious injury could occur if the tool is tipped or if the cutting tool is unintentionally contacted.
18. **CHECK DAMAGED PARTS.** Before using this machine, check to see if any parts have been damaged or came loose in transit. Do not use if the guard assembly has been damaged or machine is out of alignment in any way.
19. **DIRECTION OF FEED.** Feed work into a blade or cutter against the direction of rotation of the blade or cutter only.
20. **NEVER LEAVE TOOL RUNNING UNATTENDED. TURN POWER OFF.** Don't leave tool until it comes to a complete stop.

## Special Safety Rules for Sander

---

1. Wear eye protection.
2. Support workpiece with backstop or work table.
3. Maintain 1/16 inch maximum clearance between table and sanding belt or disc.
4. Hold the work firmly, so that it may not be driven from your hands.
5. In operation, do not press on the belt. Excessive pressure against the belt is never necessary. It will only result in damage to the belt or work piece.
6. In a home where there are small children, It is a good practice to unplug the motor and remove the drive belt when the sander is not in operation.
7. Feed workpiece against rotation of sander.
8. Connect to a supply circuit protected by a circuit breaker or time-delay fuse.
9. Fasten stand or sander base to floor before using the sander.

# Your Sander

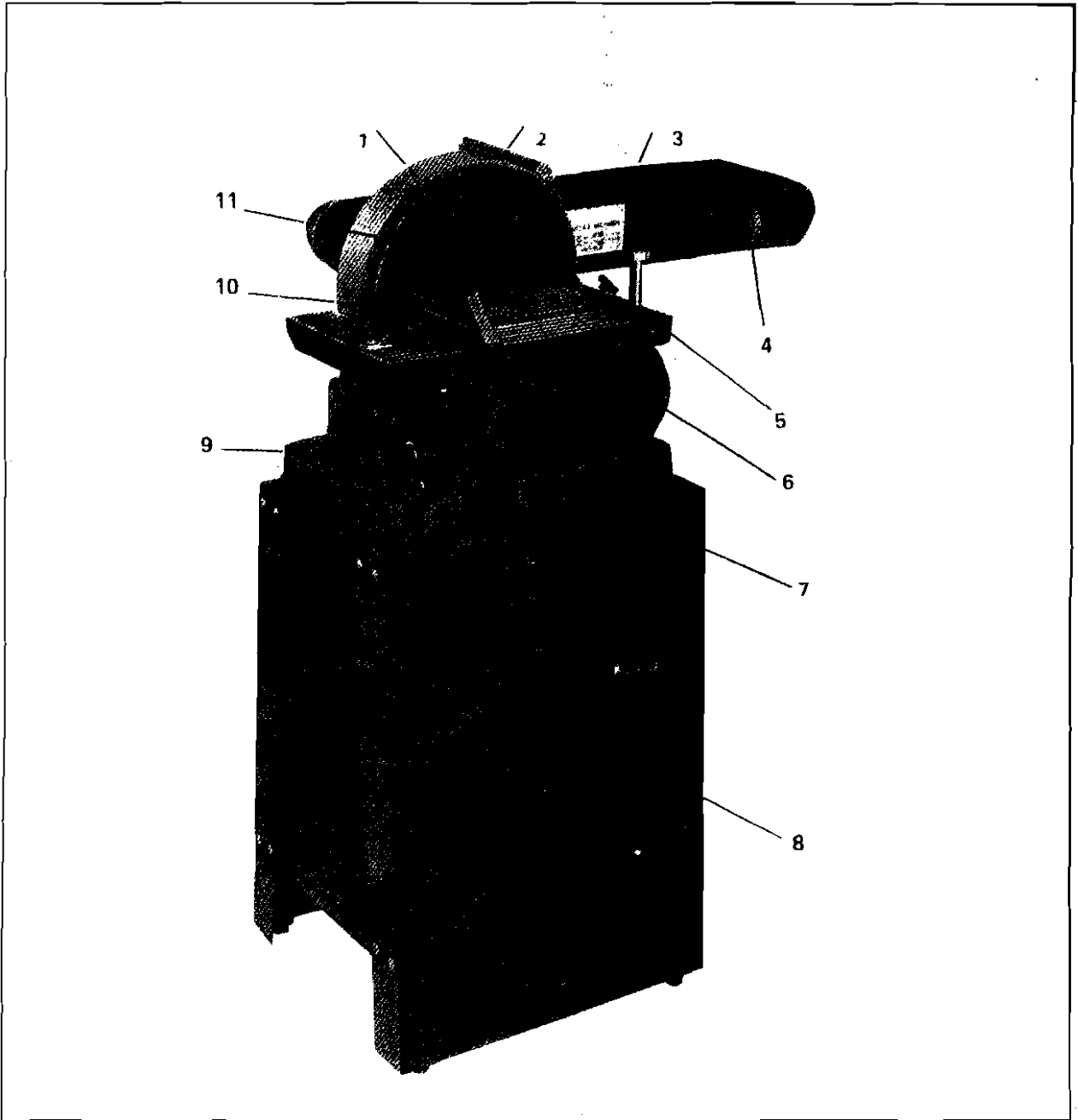

Fig. 1

- |                 |                    |
|-----------------|--------------------|
| 1. Disc guard   | 7. Table supporter |
| 2. Backstop     | 8. Stand plate     |
| 3. Sanding belt | 9. Knob            |
| 4. Adjust knob  | 10. Miter gauge    |
| 5. Work table   | 11. Sanding disc   |
| 6. Motor        |                    |

**P.3  
Unpacking**

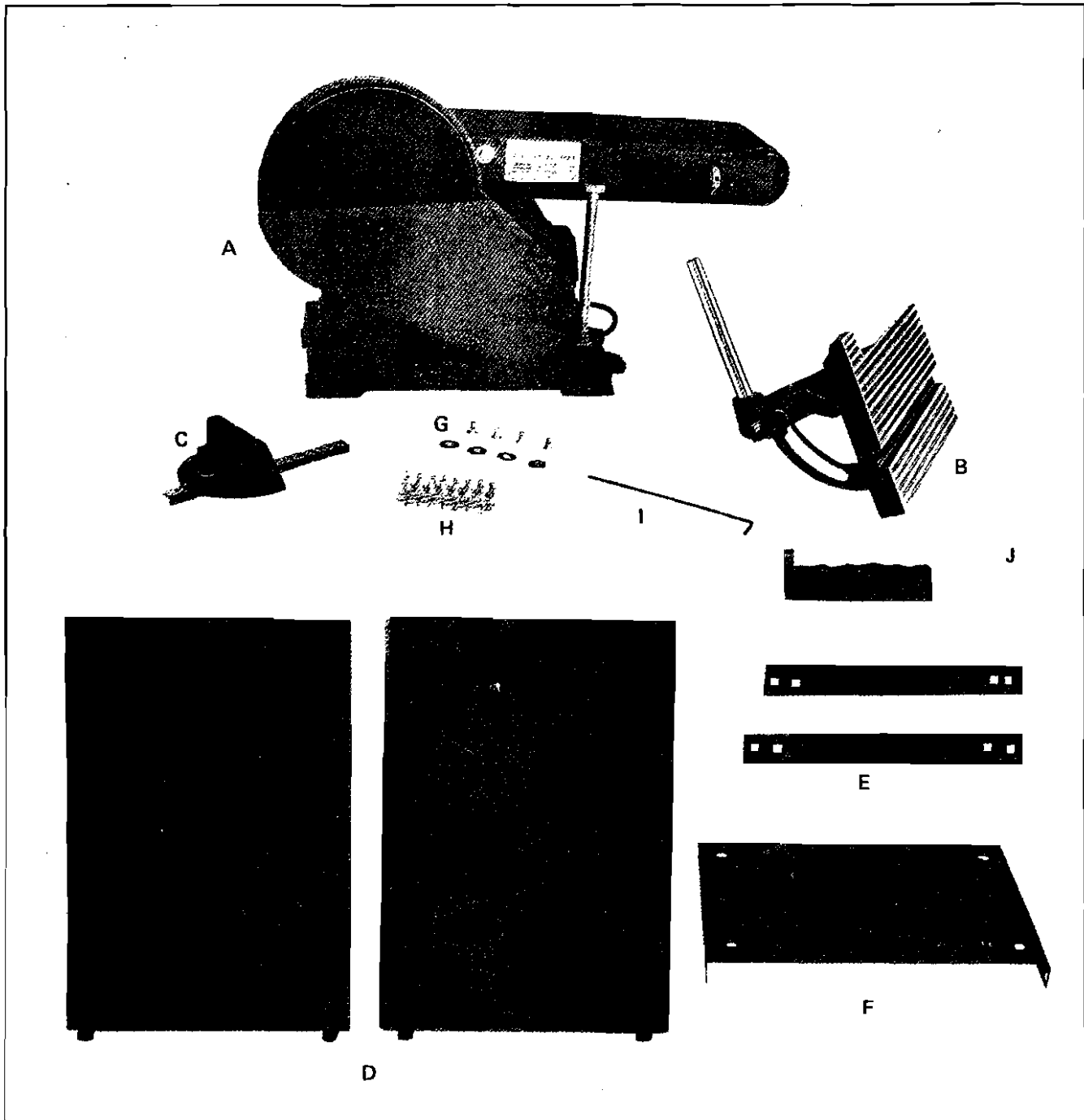

Fig. 2

Carefully unpack the sander and check all items, Figure 2 illustrates the contents of the cartor. Do not discard any packing material until the sander is fully assembled and operational.

- |                  |  |
|------------------|--|
| A. Body          | F. Lid   |
| B. Work table    | G. Bolts & washers — Screw $5/16" \times 1/2"$ — 4 pcs, Washer $5/16"$ — 4 pcs |
| C. Miter gauge   | H. Hardware package  |
| D. Stand plate   | I. Allen wrench  |
| E. Stand bracket | J. Backstop  |

### Stand

**Step 1.** Bolt the two brackets (E) to the base of the two stand plates (D) as shown in Fig. 3. Use the carriage bolts and nuts provided (hardware package). Note: Do *not* tighten bolts until stand is fully assembled.

**Step 2.** Place lid (F) on top of stand and bolt together as shown in Fig. 4. Being sure of table squareness, tighten all bolts. Turn stand upside down and install the four rubber feet in the holes in the bottom of the stand. (Fig. 4-1) Again, be sure to tighten all bolts.

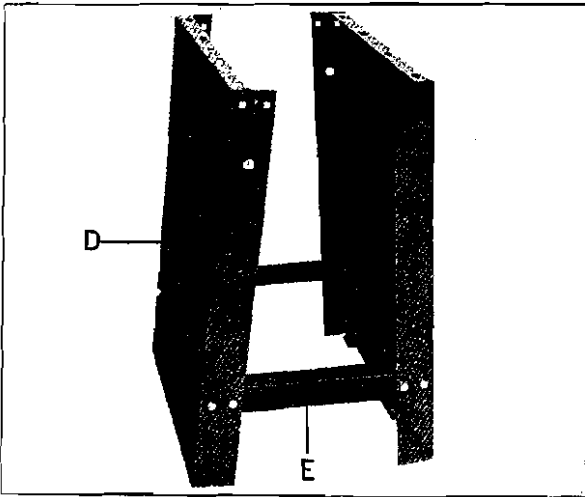

Fig. 3

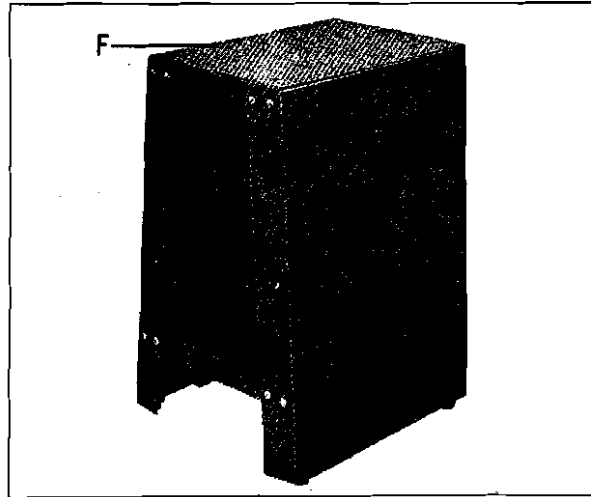

Fig. 4

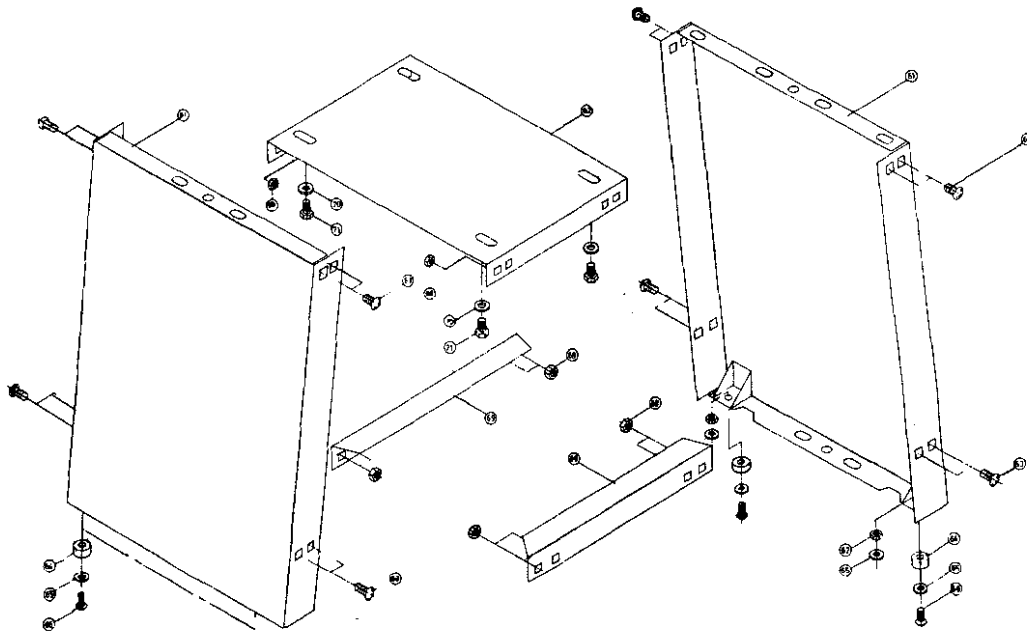

Fig. 4-1

### Attaching Belt and Disc Body to Stand

Return stand to upright position. Place body (A) on the stand as shown in Fig. 5, being sure to align the four threaded holes in the bottom of the body with the holes provided in the stand. Use the four hex bolts and washers provided (G) and secure body to stand.

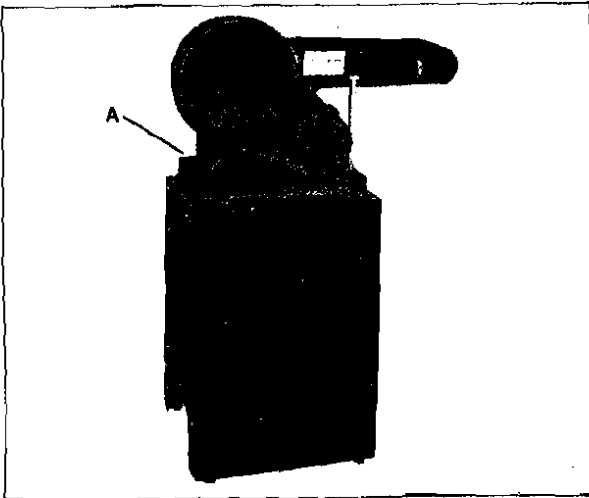

Fig. 5

### Attaching Backstop

On the side of the sanding belt table, install the hex bolt and washer (Fig. 6). Slide the backstop between the washer and the belt table and tighten as shown.



Fig. 6

### Attaching the Work Table (Fig. 7)

The work table (B) is mounted in front of the sanding disc. Locate and loosen the two set screws under and to the left of the sanding disc. Insert table rod and tighten set screws making sure the flat side of the rod faces the set screws. Be sure also to leave at least 1/16" of an inch clearance between table and disc.

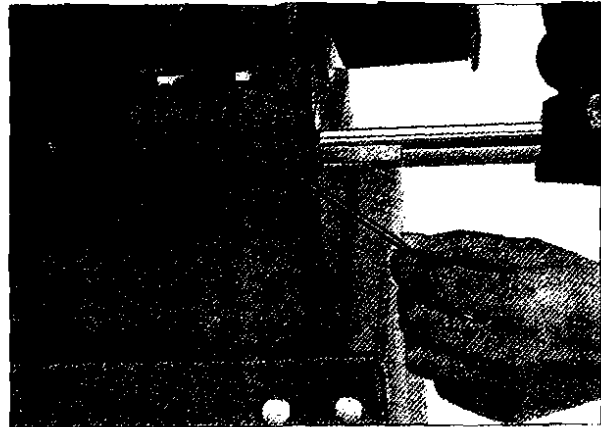

Fig. 7

### Sanding Belt Tension and Alignment

The sanding belt tension and alignment can be adjusted by using the two thumb wheels located on either side of the sanding belt. You may find the wheels too difficult to turn by hand. Use the allen wrench for leverage. Wheels have holes for this purpose (See Fig. 8.) Proper tension and alignment of belt is critical for efficient operation, but simple to accomplish. If belt is too loose, it will not track properly, and will slip on pulley assembly under pressure. If the belt is too tight, it will run erratically and will also strain the motor. It is not necessary to stretch the belt. Apply only enough pressure to push pulleys firmly against belt. Adjust wheels alternately to track belt properly (run centered on pulleys and table). Be sure belt is running smooth and straight.

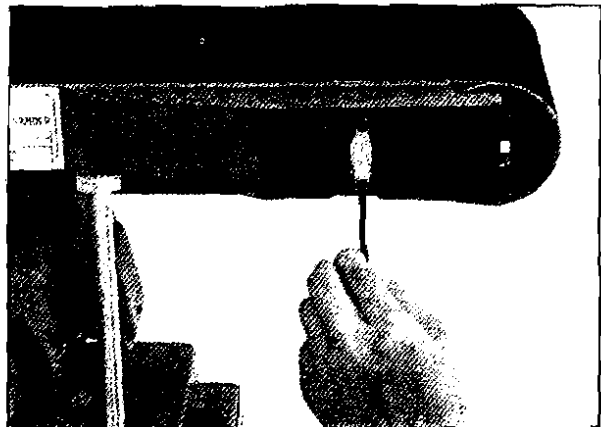

Fig. 8

### ***Belt Replacement***

To replace belt, simply back off on the thumb wheels, loosening the belt tension enough to slide belt off of pulleys (Fig. 9). Slide new belt on and return the belt to the proper tension and tracking as explained in **sanding belt tension and alignment** section.

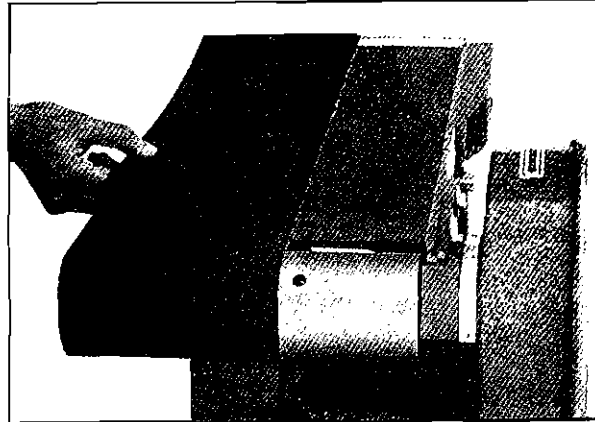

Fig. 9

### ***Disc Replacement***

**Step 1.** First remove work table. Remove knob on disc cover (Fig. 10). Open disc cover. Tear off old sanding disc. You may need to use mineral spirits and a putty knife if the disc has been on for an extended period. Take care *not* to scratch aluminum disc plate. Clean off all remaining glue from plate.

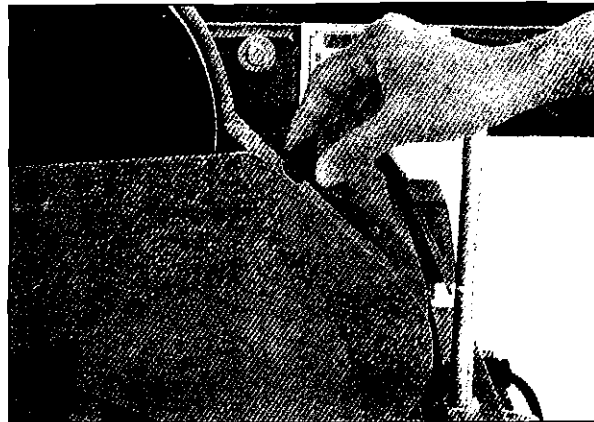

Fig. 10

**Step 2.** Center new disc on plate (Fig. 11). Some discs may not have adequate adhesive. There are many spray adhesives on the market for this purpose.

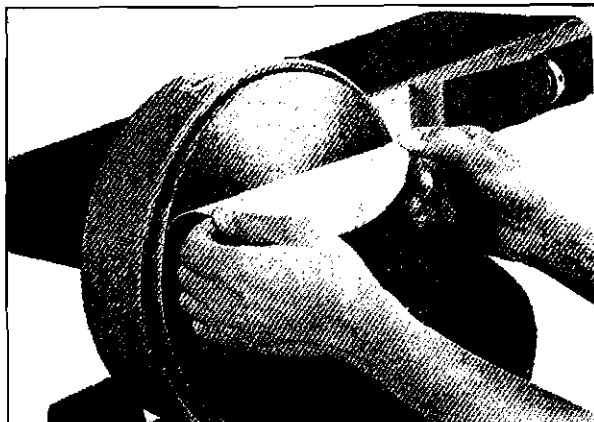

Fig. 11

### V-Belt Replacement

To replace V-belt, remove work table and drop dust cover as explained in Fig. 10. Loosen the four motor mounting bolts at base of motor. Slide motor towards the disc. At the underside of the disc housing, locate rectangular window (Fig. 12). Insert allen wrench. With your hand, spin disc until the set screw holding the disc facing down, then insert allen wrench and loosen set screw. Slide off disc. Remove old belt, or any pieces of broken belt. Place new V-belt on disc pulley and slide it back onto the arbor. Replace disc. Tighten set screw. **Note:** Be sure disc pulley and motor pulley are perfectly aligned to minimize V-belt and motor wear. Place V-belt onto motor pulley, and slide motor back to original position for proper belt tension. Return disc cover and work table to original positions.

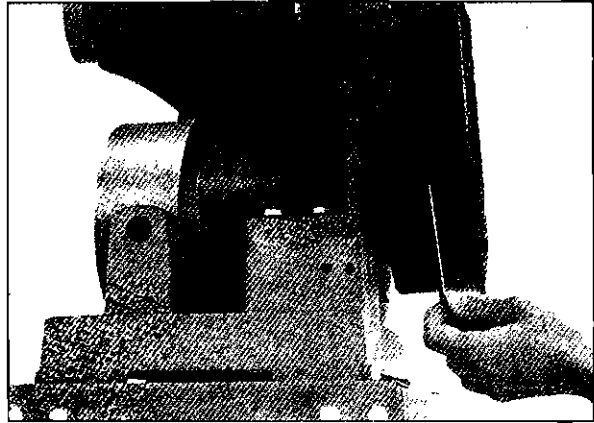

Fig. 12

### Work Table Angle

Work table can be adjusted from 0°-45° by loosening adjustment knob located under and to the left of the table (Fig. 13). Simply tighten at desired angle.

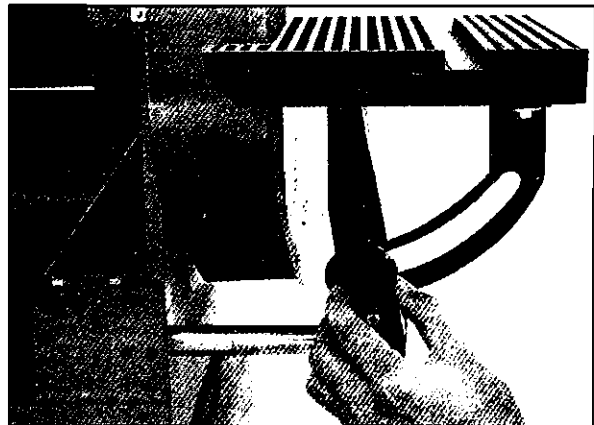

Fig. 13

### Sanding Belt Angle

The sanding belt can be operated at a full vertical position, or any position in between. On the back side of the disc cover are two nuts. Figure 14 shows one, arrow shows location of second. Loosen these, raise belt and tighten nuts at desired angle.

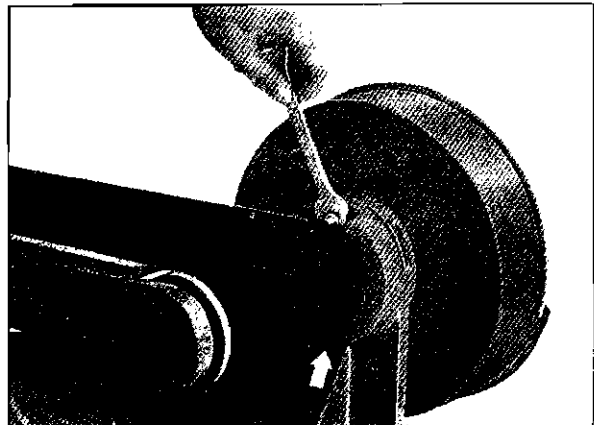

Fig. 14

**Note:** With the belt in vertical position, you may use the work table. See Fig. 18. Simply remove work table from disc location and slide table rod into hole provided in front, at base of belt, as shown in Fig. 15. Again, be sure of the 1/16" clearance between table and sander.



**Fig. 15**

## **Operation**

**Safety Note:** Be sure all objects are removed from belt, disc, and work table area before starting machine. Read safety rules in front of manual.

### **Horizontal Sanding**

See Fig. 16. Place work piece on belt up against the back stop. (Always be aware of where your hands are). Do not apply too much pressure during sanding procedure, as the belt works best without excessive force.

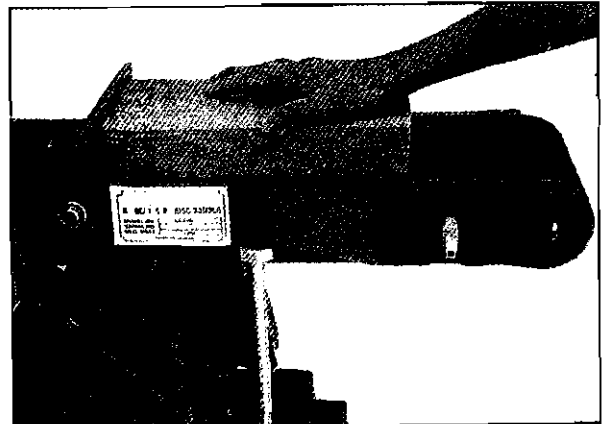

**Fig. 16**

### **Sanding Curved Surfaces**

You can use the end of the belt pulley (Fig. 17) to accommodate curved surfaces.

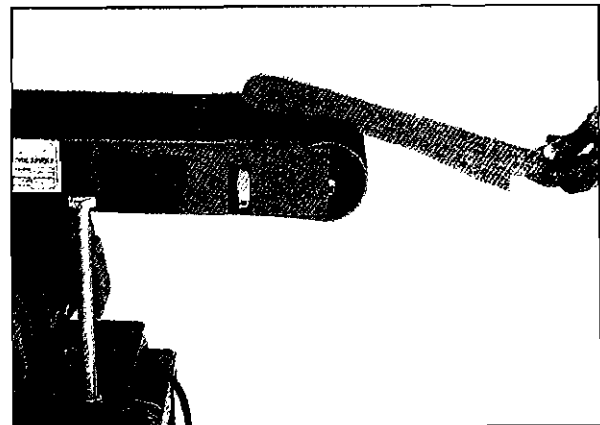

**Fig. 17**

### ***Vertical Sanding***

To sand the end of the workpiece, use the vertical belt position. The work table will aid you much better for this operation than the back stop (Fig. 18).

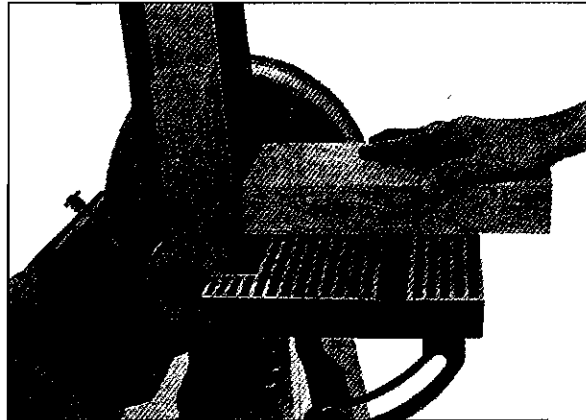

Fig. 18

### ***Disc Sanding***

Place workpiece on table as shown in Fig. 19. Always be aware of rotation direction of disc. Caution : The work piece can lift off the table on the upstroke of the disc.

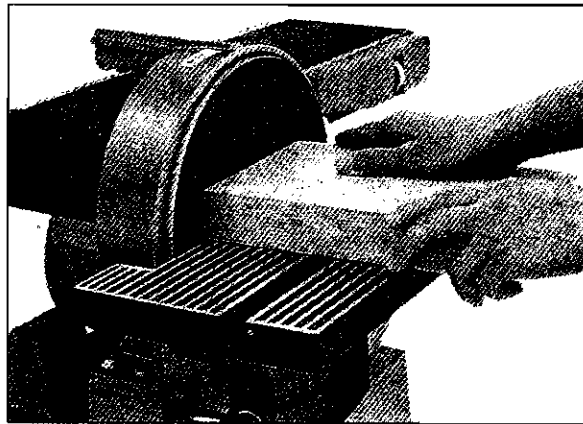

Fig. 19

### ***Bevel Sanding***

Adjust work table to desired angle as explained in Fig. 13. Be sure of 1/16" clearance and tighten all knobs and bolts before operating. See (Fig. 20).

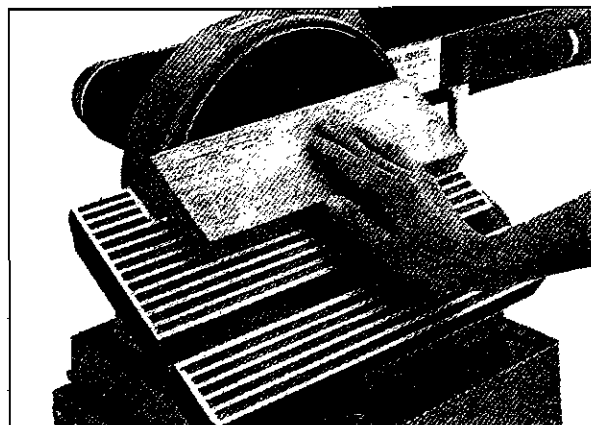

Fig. 20

## P.10

### Miter Sanding

You can use your miter gauge to assist in sanding angles up to 60°, as shown in Fig. 21. Be sure to tighten miter gauge knob securely.

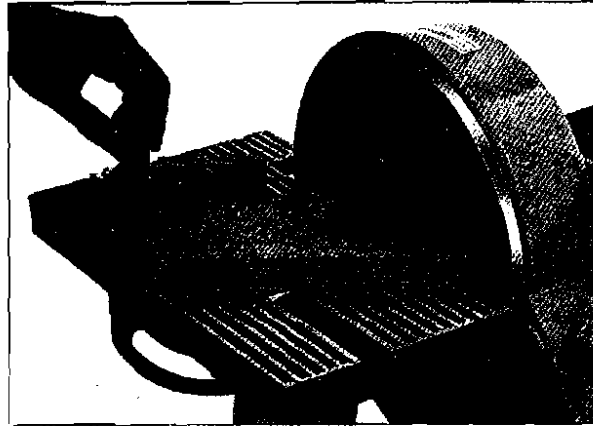
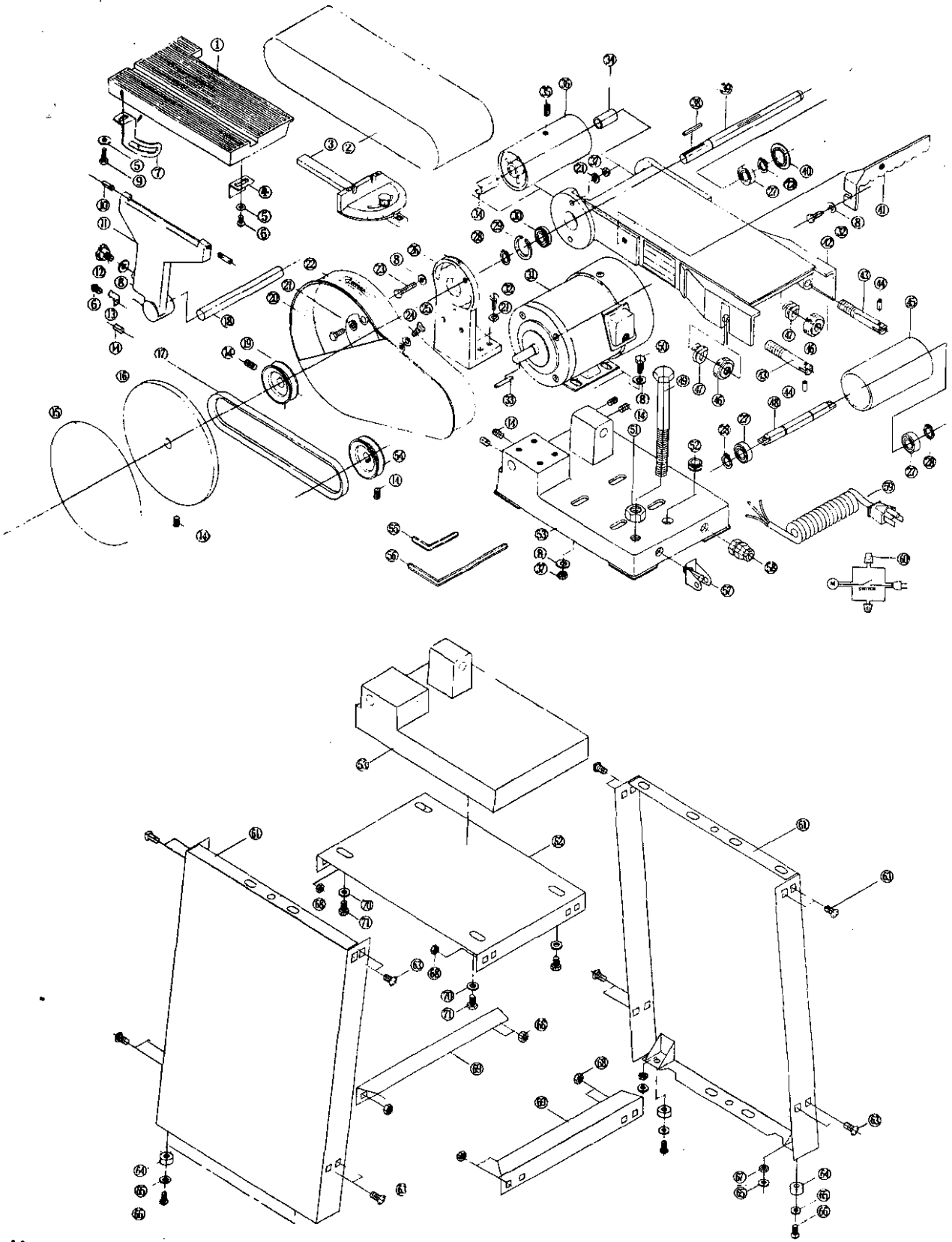

Fig. 21

## Technical Data

Table Size	12 3/8 x 6 1/4	Disc Size	9" diameter
Table Angle	0° - 45°	Disc Rotation Speed	1725 RPM
Belt Size	6" x 48"	Motor Specifications	3/4 HP 10/5 amps. 110/220 volts
Belt Angle	0° - 90°	Dimensions	39" high x 29" long x 20" wide
Belt Speed	2100 feet per minute	Net Weight	105 lbs.

# Assembly Diagram and Parts List



**P.12**

Parts No.	Description	Unit	Parts No.	Description	Unit
1	Table	1	39	Driving roller shaft	1
2	Sand belt 48"	1	40	Rubber cover	1
3	Miter gauge	1	41	Back stop	1
7	Angle gauge	1	42	Sand belt frame	1
8	Washer 5/16"	13	43	Roller adjust bar	2
9	Screw 5/16"x3/4"	1	44	Spring pin $\phi$ 5	2
10	Pin	2	45	Idler roller	1
11	Table support bracket	1	46	Adjust nut	2
12	Knob 5/16"x5/8"	1	47	Spring	2
13	Pointer	1	48	Idler roller shaft	1
14	Set screw 5/16"x3/8"	11	49	Support bolt 5/8"x9-1/2"	1
15	Sand paper	1	50	Screw 5/16"x3/4"	4
16	Sand disc	1	51	Nut 5/8"	1
17	V-belt A-25	1	52	Cord clamp	2
18	Support bar	1	53	Base	1
19	Pulley 15mm	1	54	Pulley 16mm	1
20	Screw 5/16"x1/2"	3	55	Hex wrench	1
21	Spring washer 5/16"	9	56	Hex wrench	1
22	Pulley cover	1	57	Switch	1
23	Screw 5/16"x1.5/8"	2	58	Cord clamp	2
24	Washer 3/16"	1	59	Power cord	1
25	Knob 3/16"x3/8"	1	60	Wire connector	2
26	Bracket	1	61	Stand	2
27	Ball bearing 6201 ZZ	3	62	Stand plate	1
28	Retaining ring S12	3	63	Carriage Bolts 5/16" X 1/2"	16
29	C-snap ring S35	1	64	Rubber	4
30	Ball bearing 6202ZZ	1	65	Washer 1/4"	8
31	Motor	1	66	Screw 1/4"x3/8"	4
32	Screw 5/16"x1"	5	67	Nut 1/4"	4
33	Key 5x5x20	1	68	Nut 5/16"	16
34	Tube	2	69	Frame	2
35	Set screw 5/16"x3/8"	2	70	Washer 5/16"	4
36	Driving roller	1	71	Screw 5/16"x1/2"	4
37	Nut 5/16"	6	72	Retaining ring S15	1
38	Key 5x5x50	1			